



Control Methods of LLC Converters

Christophe Basso

Business Development Manager

IEEE Senior Member

Agenda

- Hard and Soft Switching
- What is an LLC Converter?
- Controlling the Switching Frequency
- Closing the Loop
- Charge-Controlled Operation I
- Charge-Controlled Operation II
- Current-Mode Control
- Time-Shift Control
- An Overview of Available LLC Controllers

Hard-Switching Operations without Parasitics

- A switching circuit without parasitics operates safely within maximum ratings

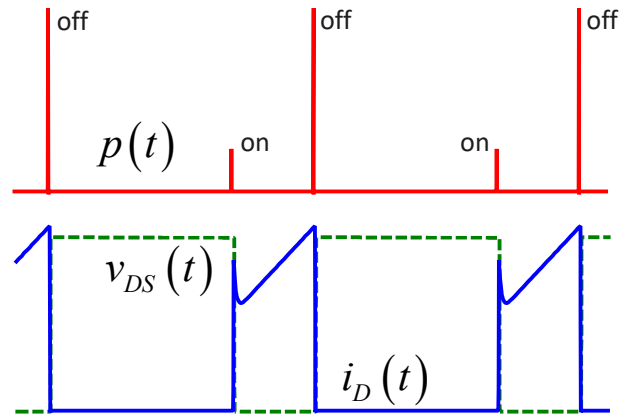
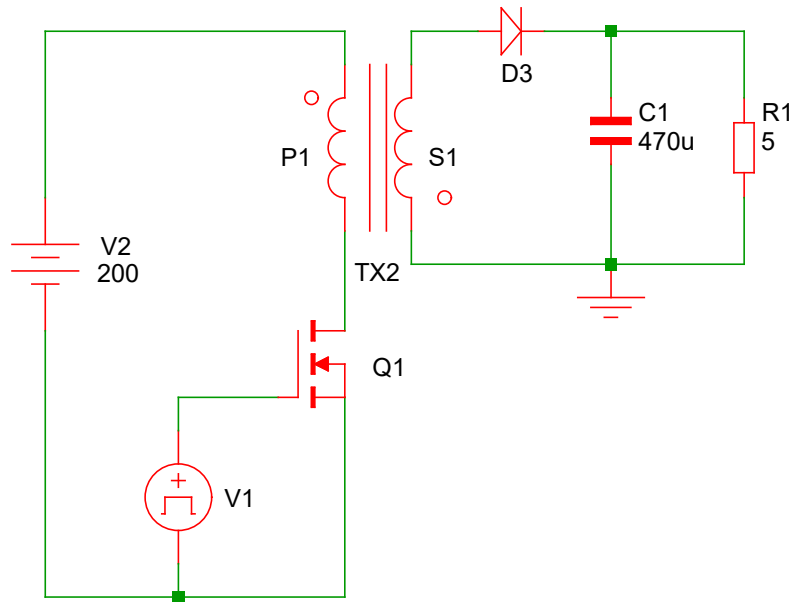

- Overlap between current and voltage is minimum and keeps switching losses low

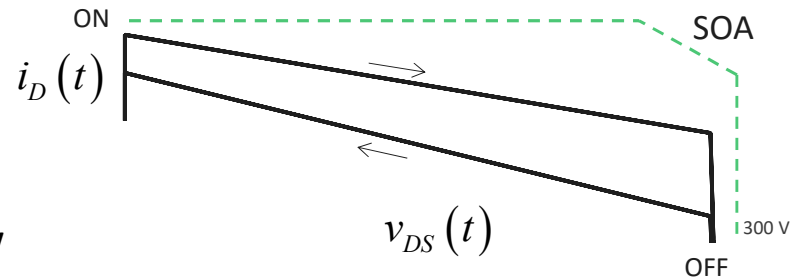

SOA: safe operating area

Parasitics degrade Switching Performance

- Parasitics add oscillatory phenomena and safe limits can be violated

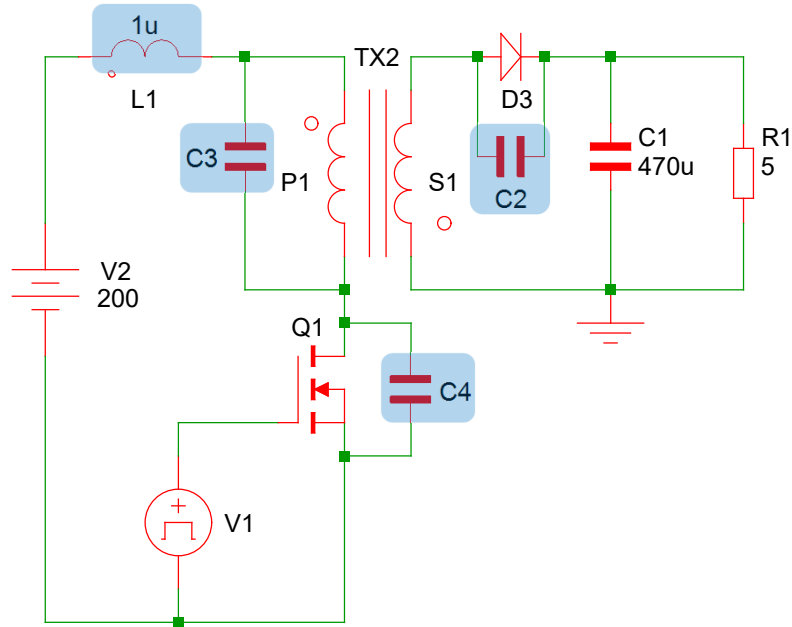

- Leakage inductance brings the v_{DS} outside of the safe operating area
- Switching losses scale up with frequency

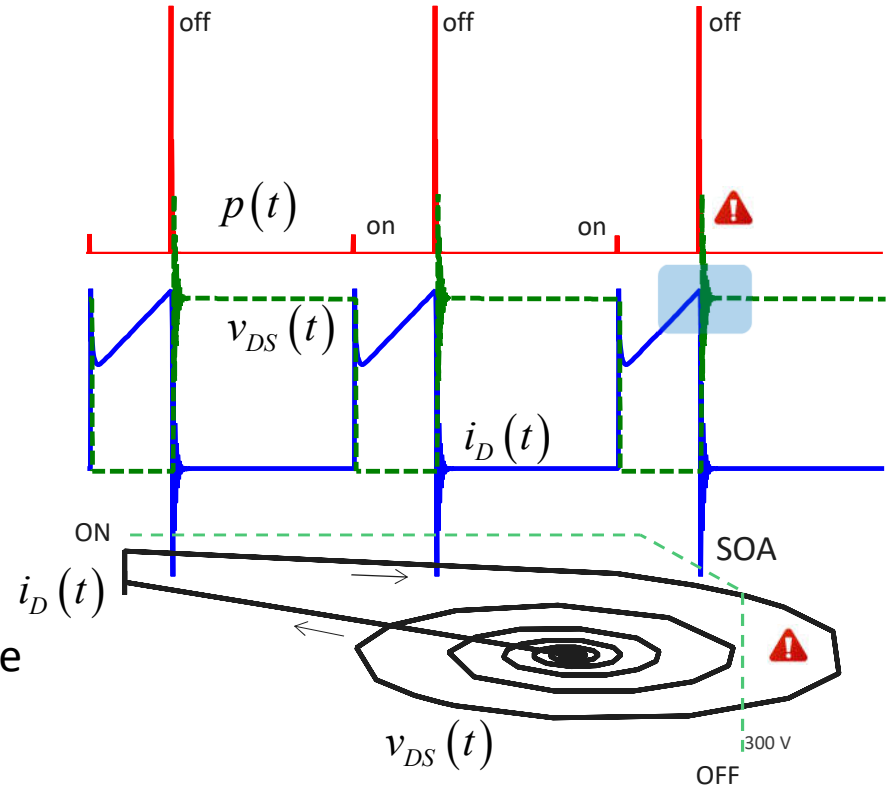

Voltage Excursion must be Clamped

- Dampers and snubbers efficiently calm down oscillations

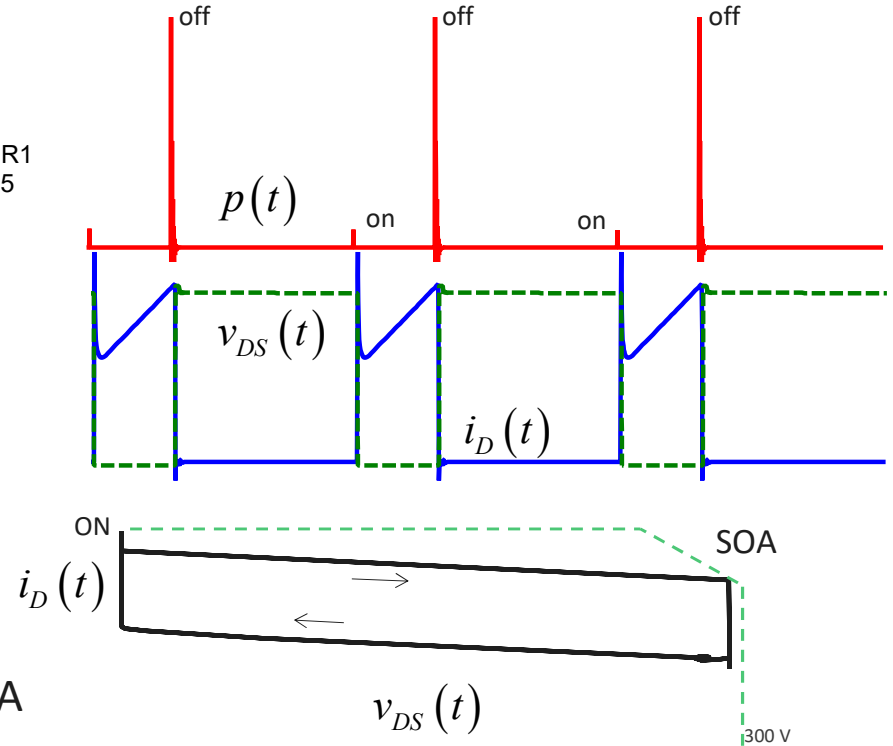
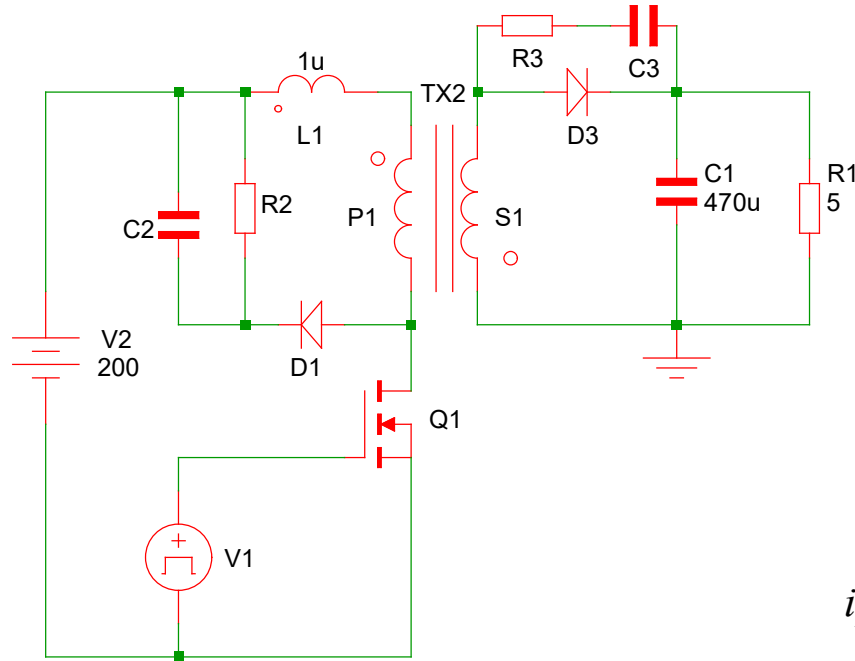

- The voltage excursion is back into the SOA
- ❖ Power dissipation is still there with dampers

Resonant Waveforms Smooth Switching Events

- Quasi-resonance operation brings near-zero-voltage transition

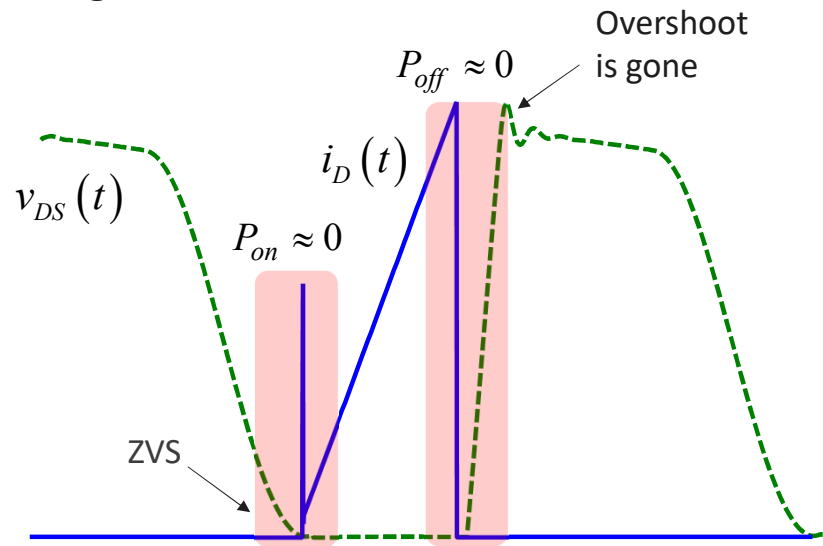
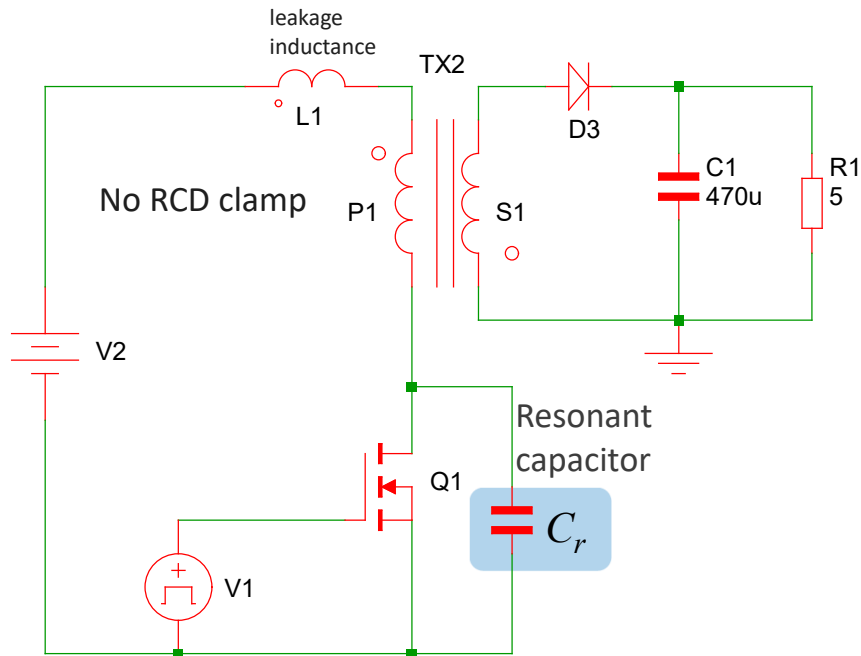

- Capacitor C_r ensures a slowly-rising $v_{DS}(t)$ at turn off
- ✓ The overlap I-V has disappeared, and turn-off loss is 0 W
- The oscillation involving L_m ensures C_r discharge to 0 V
- ✓ Zero-voltage switching cancels turn-on loss

Soft Switching Definitions – ZCS

- Reverse recovery occurs when the diode is hard-blocked by a negative voltage

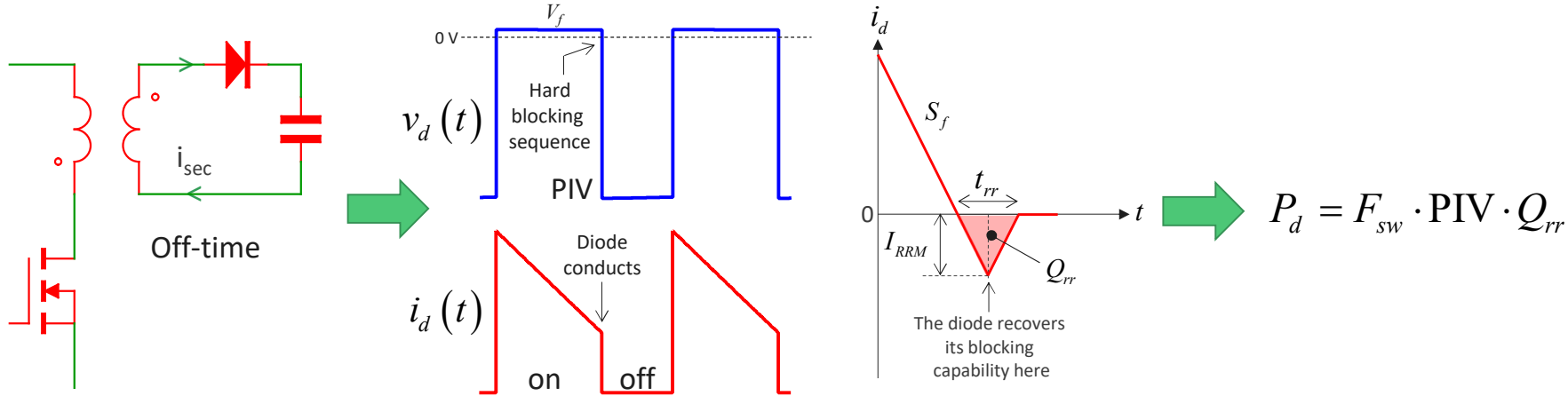

- Zero-current switching or ZCS implies a turn-off mechanism initiated at zero current

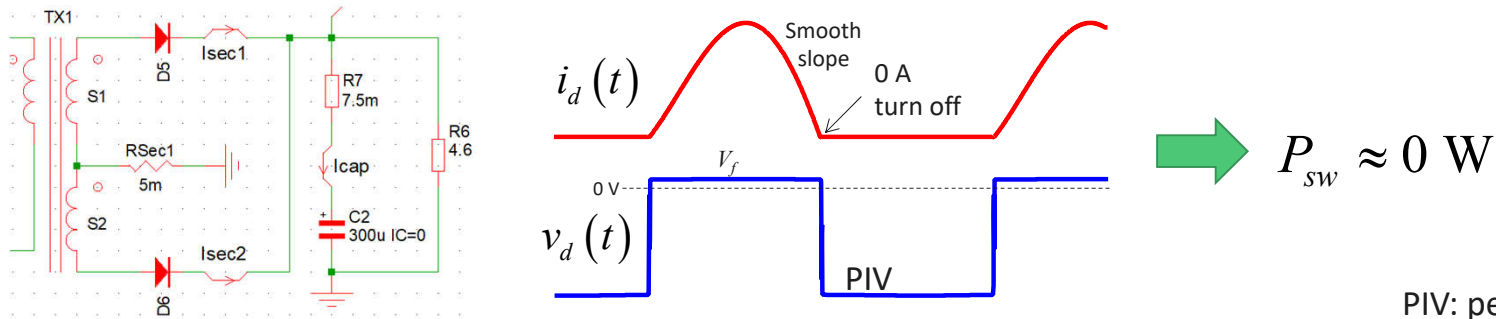

PIV: peak inverse voltage

Agenda

- Hard and Soft Switching
- What is an LLC Converter?
- Controlling the Switching Frequency
- Closing the Loop
- Charge-Controlled Operation I
- Charge-Controlled Operation II
- Current-Mode Control
- Time-Shift Control
- An Overview of Available LLC Controllers

What is an LLC Converter?

- The LLC converter is a member of the series-resonant converters family
- The magnetizing inductance L_m is part of the resonating elements (L)
- The transformer leakage inductance or an extra inductor forms the term L_s (L)
- A series capacitor C_s is inserted to form the complete resonant converter (C)

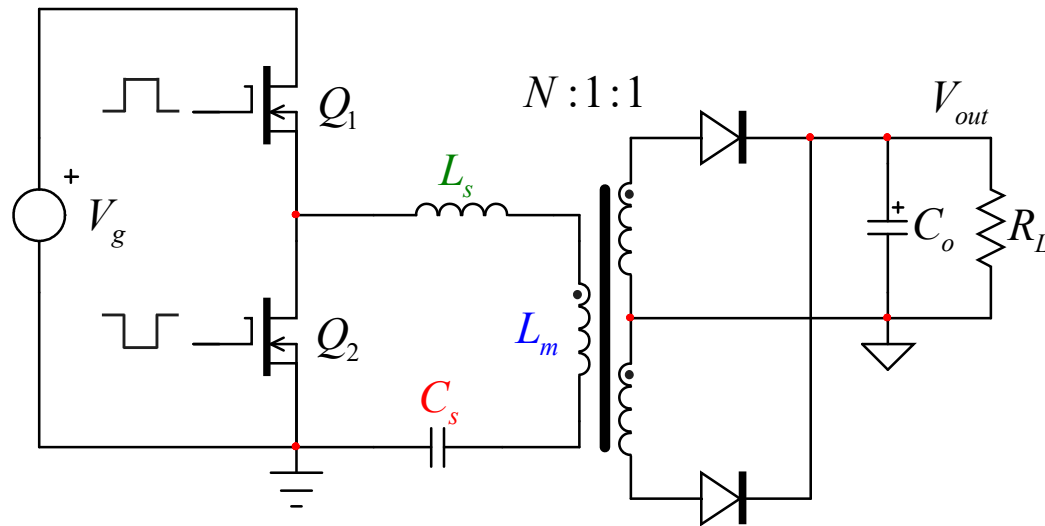

The Benefits of the LLC Converter

- The LLC converter offers soft-switching conditions in normal-load conditions
- ✓ Zero-voltage switching (ZVS) for the switches in the primary side
- ✓ Zero-current switching (ZCS) for the secondary-side diodes
- It can operate at high switching frequency to build compact converters
- ✓ Perfect for flat-panel displays like LCD TVs, game stations, servers power supplies

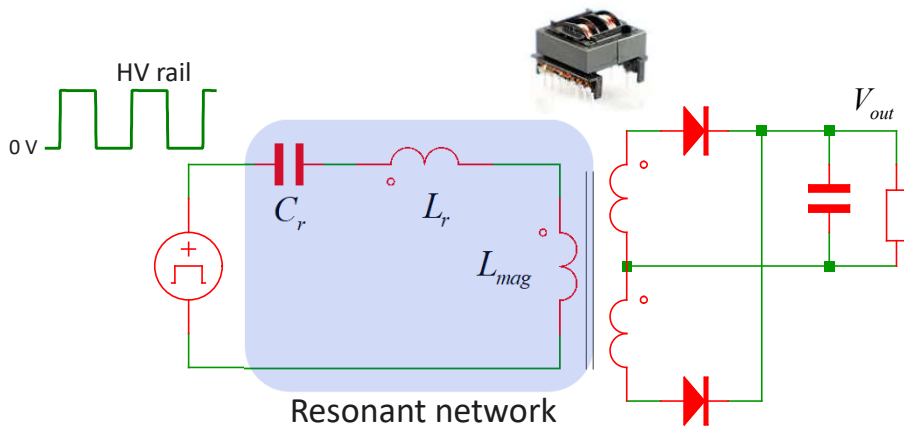

- ✓ Three energy-storing elements, C_r , L_r and the transformer magnetizing inductance L_{mag}
- ✓ Components count is limited especially if integrated magnetics is adopted

Different Configurations for the LLC - Primary

- The LLC converter can be operated in half- or full-bridge configuration

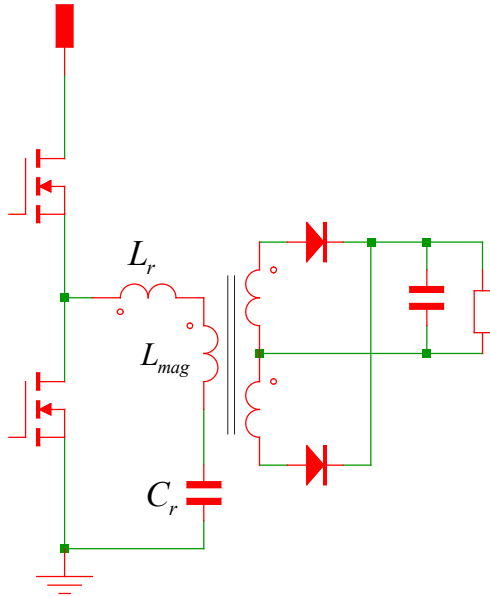

- Power up to 600 W

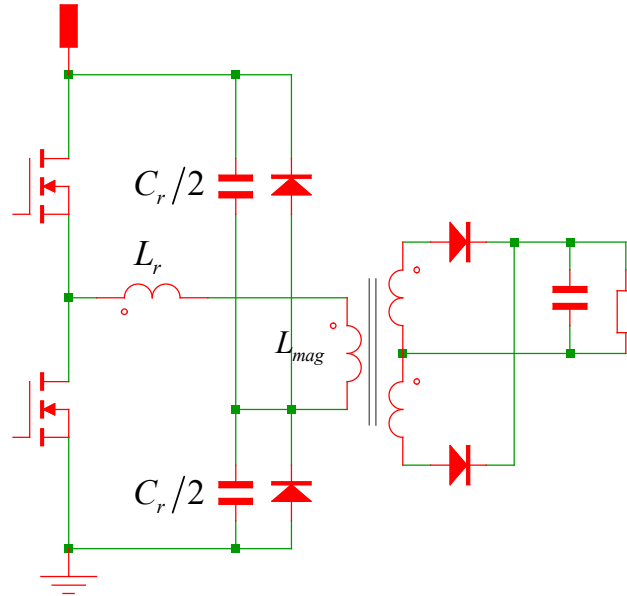

- Robust version with clamp diodes
- ✓ Lower input ripple current
- ✓ Half rms current in a capacitor

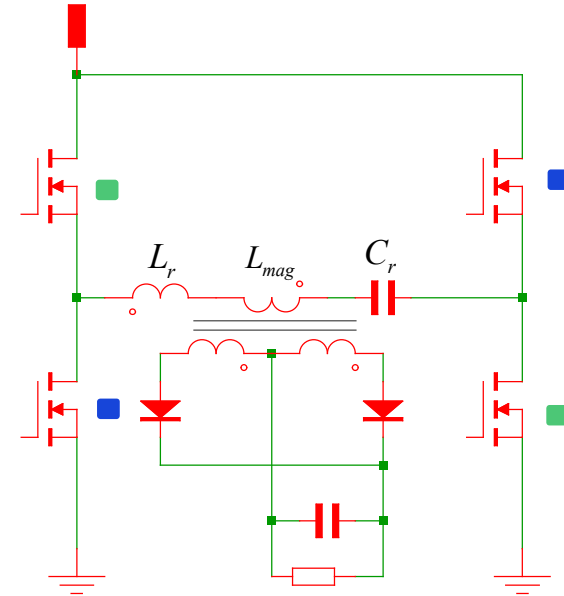

- Power beyond 1 kW
- ✓ Diagonal conduction

Different Configurations for the LLC - Secondary

- A full-bridge rectifier requires diodes with a lower breakdown voltage

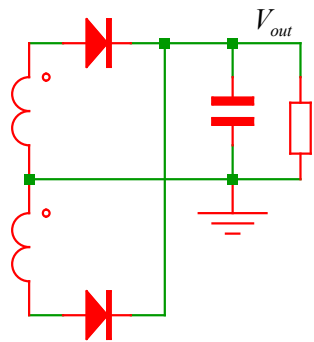

- Two separate windings
- $BV > 2V_{out}$
- Secondary leakage brings current imbalance

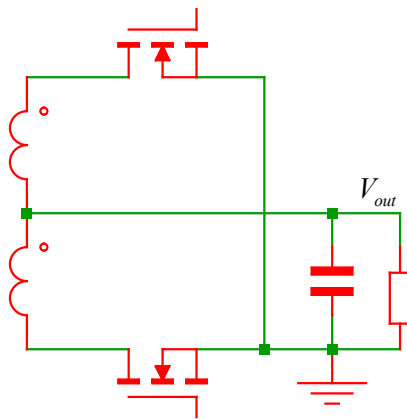

- Synchronous rectification

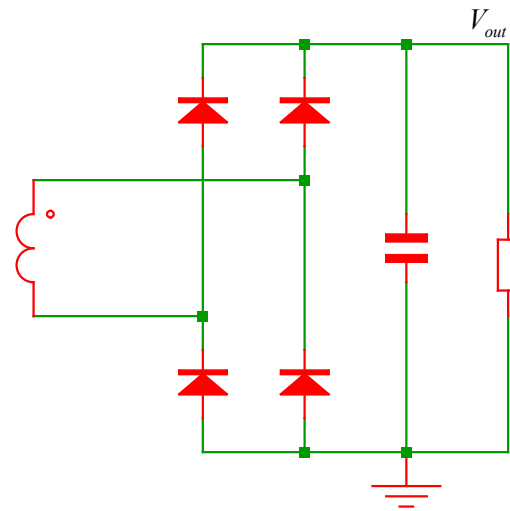

- One single winding
- $BV > V_{out}$
- No current imbalance

Synchronous Rectification Controllers

- Controllers are available to drive synchronous switches in LLC converters

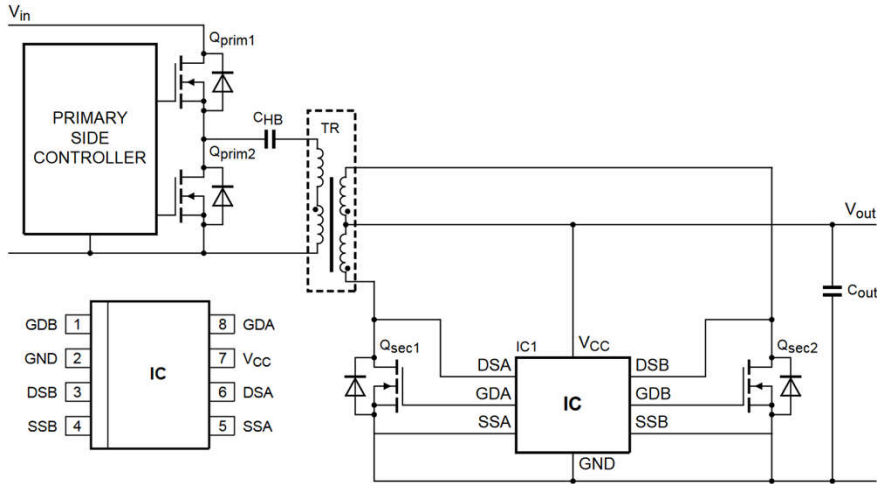

TEA2095 120 V
TEA2096 200 V

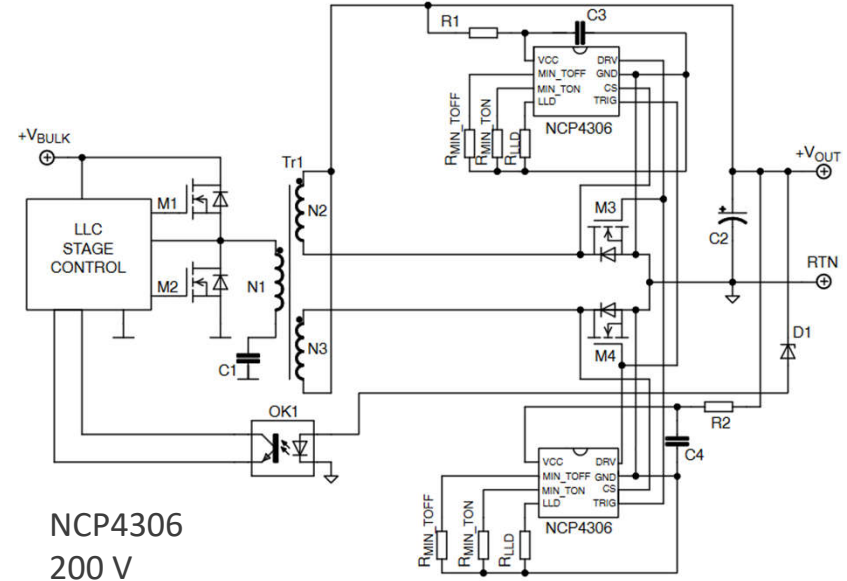

NCP4306
200 V

Bidirectional LLC Converter

- It is possible to operate the LLC in reverse for a bidirectional implementation

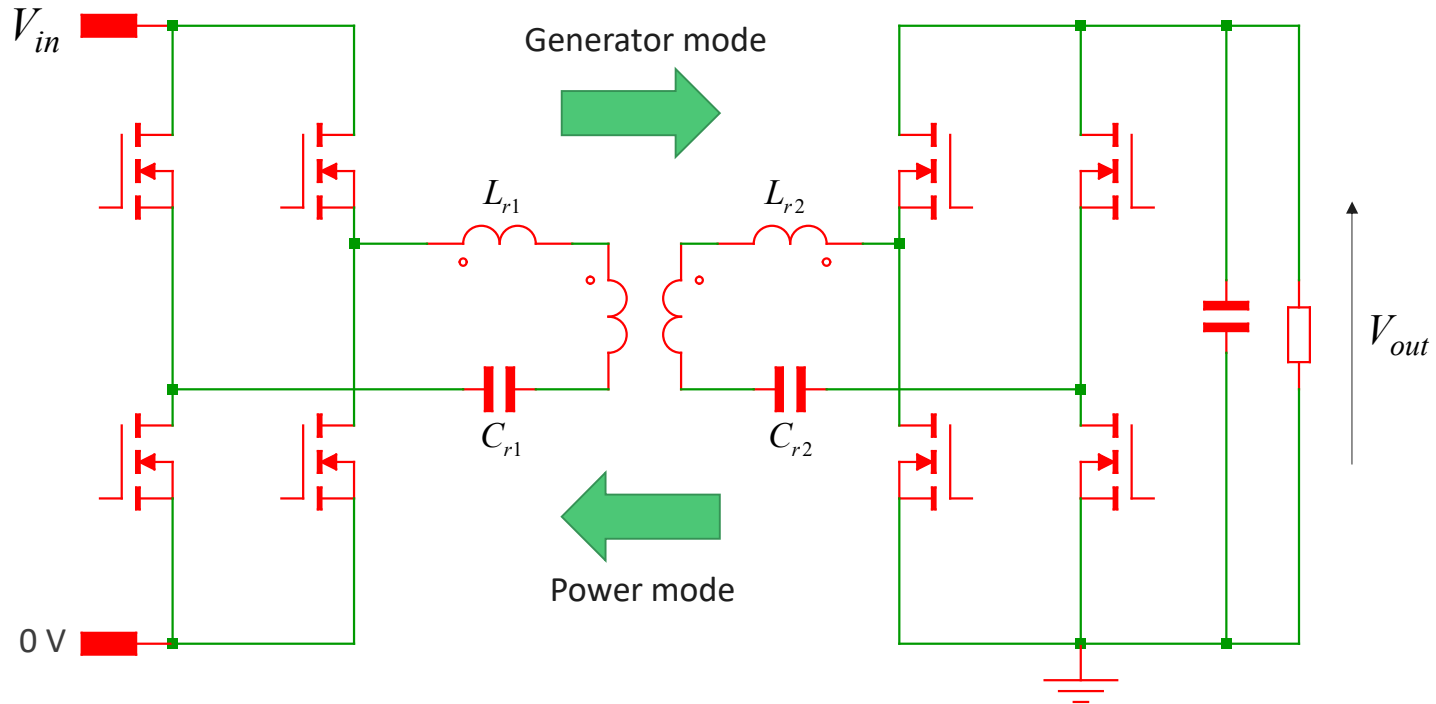

- A control circuitry observes V_{out} and determines the charging direction

Agenda

- Hard and Soft Switching
- What is an LLC Converter?
- **Controlling the Switching Frequency**
- Closing the Loop
- Charge-Controlled Operation I
- Charge-Controlled Operation II
- Current-Mode Control
- Time-Shift Control
- An Overview of Available LLC Controllers

Voltage-Mode Control

- An LLC converter is typically operated from a 50% high-voltage square waveform
- The power flow is then adjusted by varying the switching frequency
- Soft-switching on MOSFETs and diodes depends on frequency with respect to f_s

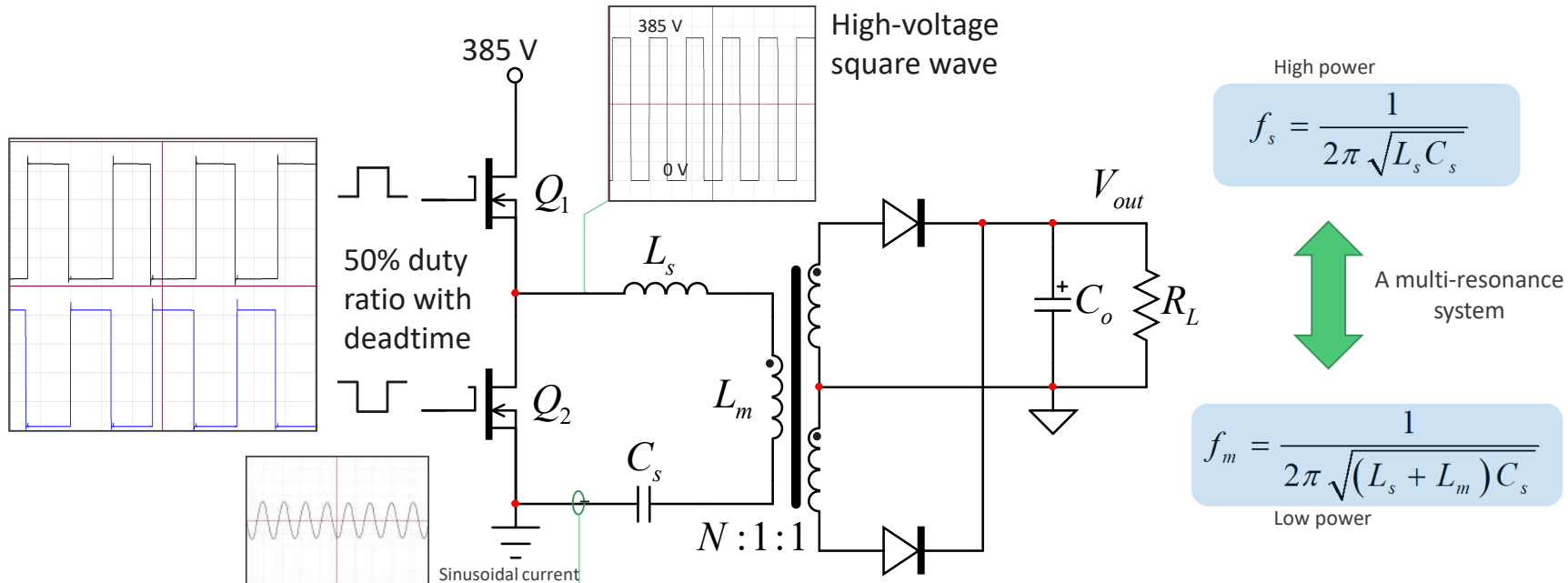

The Resonance varies with the Output Power

- The LLC converter is a multi-resonance converter depending on operating conditions
- In heavy-load condition, L_s dominates the resonant tank as L_m is shunted by R_{ac}
- In lighter-load operations, L_m and L_s together set the resonant frequency

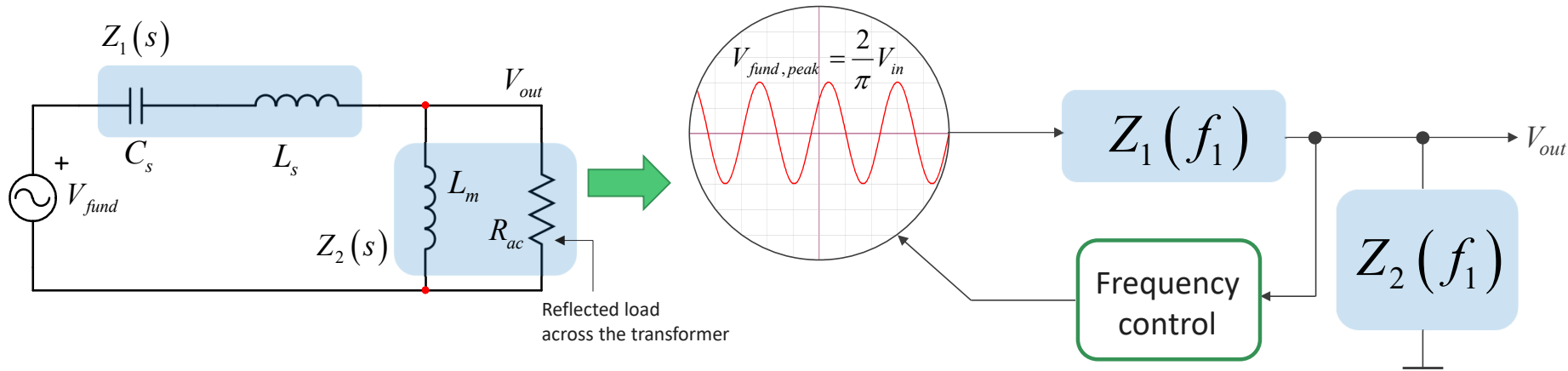

- The converter is modeled using the first harmonic approximation or FHA

Output Voltage of an LLC Converter

- The equivalent network is fed by the square-wave fundamental value according to FHA
- ✓ Determine the output voltage with the transfer function of the 3rd-order network

$$H_{m1}(s) := \frac{1}{N_{ps}} \cdot \frac{\frac{L_3}{L_2} \cdot \left(\frac{s}{\omega_s}\right)^2}{1 + s \cdot \frac{L_3}{R_1} + \left(\frac{s}{\omega_m}\right)^2 + s^3 \cdot \frac{L_3}{L_2 \cdot Q_1 \cdot \omega_s^3}}$$

$$V_{out} := V_{fund} \cdot \left| H_{ref}(i \cdot 2\pi \cdot F_{sw}) \right| = 45.19774V$$

$$v_{fund,rms} = \frac{2V_{in}}{\pi} \cdot \frac{1}{\sqrt{2}} = \frac{\sqrt{2}V_{in}}{\pi} \approx 173 \text{ V rms}$$

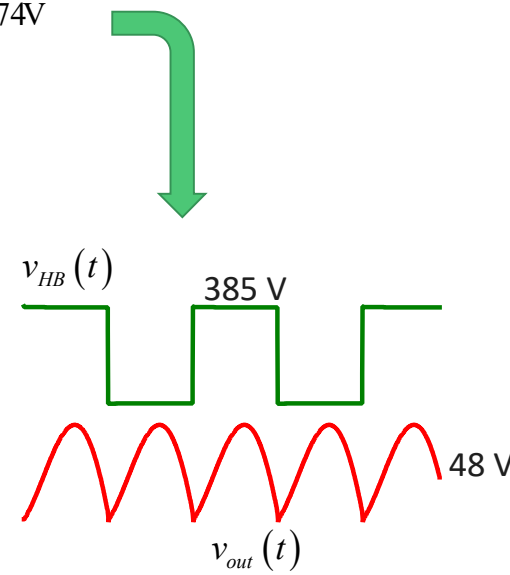
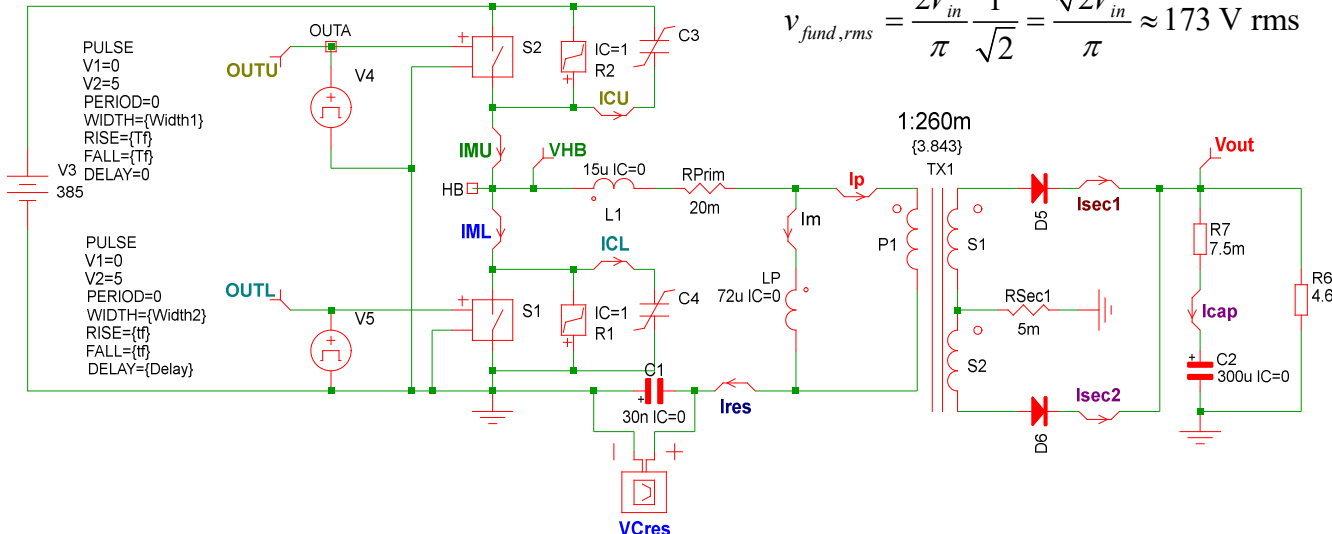

A Complex Input Impedance

- The impedance offered by the network to the half-bridge shows two main zones:
 - ❖ A capacitive region: $F_T < F_{\min}$
 - ❖ An inductive region: $F_T > F_{\min}$

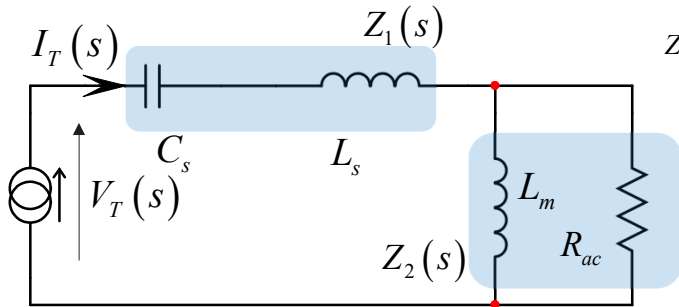

$$Z_{in}(s) = \frac{V_T(s)}{I_T(s)}$$

(dBΩ)

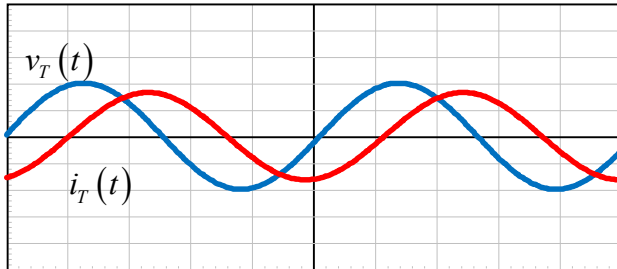

Voltage and current in the inductive region

Impedance of the series resonant network

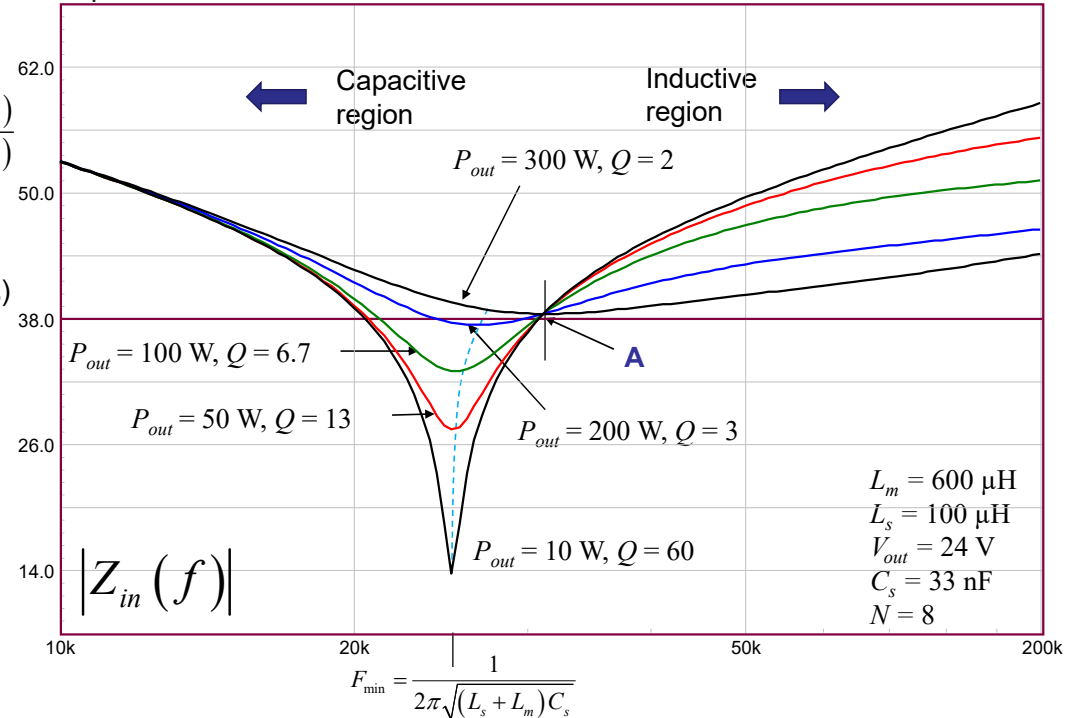

Where to Operate the Converter?

- Plotting the dc transfer characteristic of the LLC network reveals several points

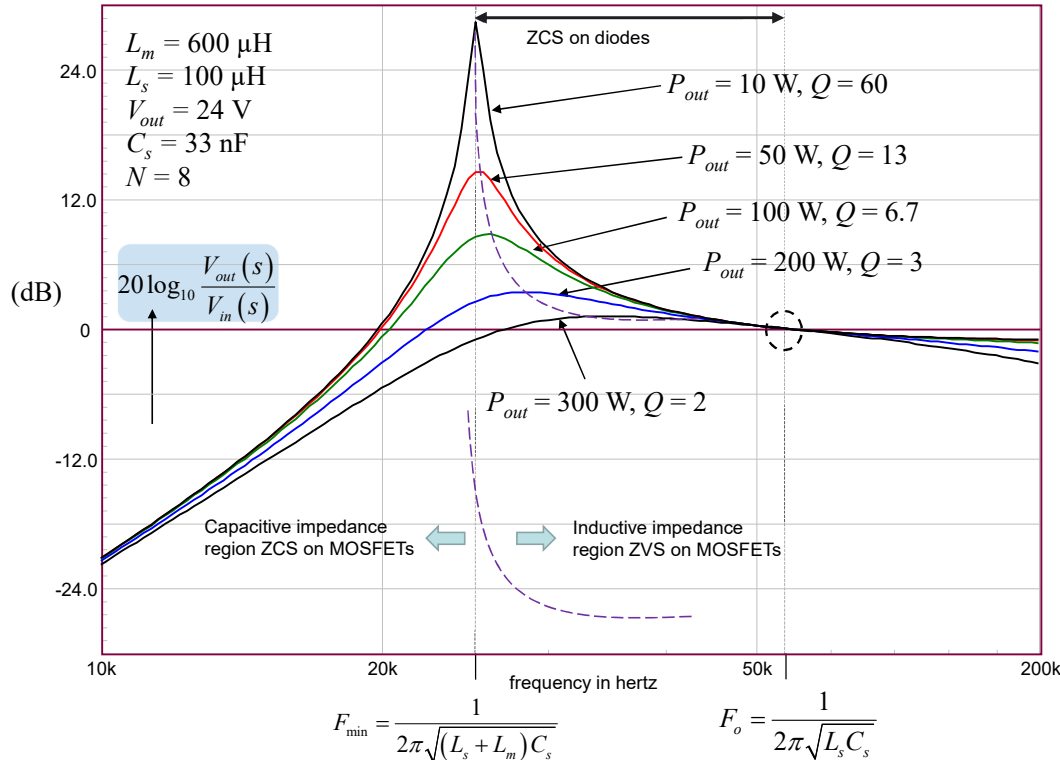

- ✓ As load current decreases, L_m enters the picture and brings a second peak
- ✓ An impedance plot shows so-called **capacitive** and **inductive** regions
- ✓ The inductive region brings ZVS on power MOSFETs and ZCS on output diodes
- ✓ ZCS on MOSFETs is occurring in the capacitive region but the control law changes!

Observing Waveforms tells us the Operating Region

- Resonating current i_r is a perfect sinewave when LLC operates at resonant frequency

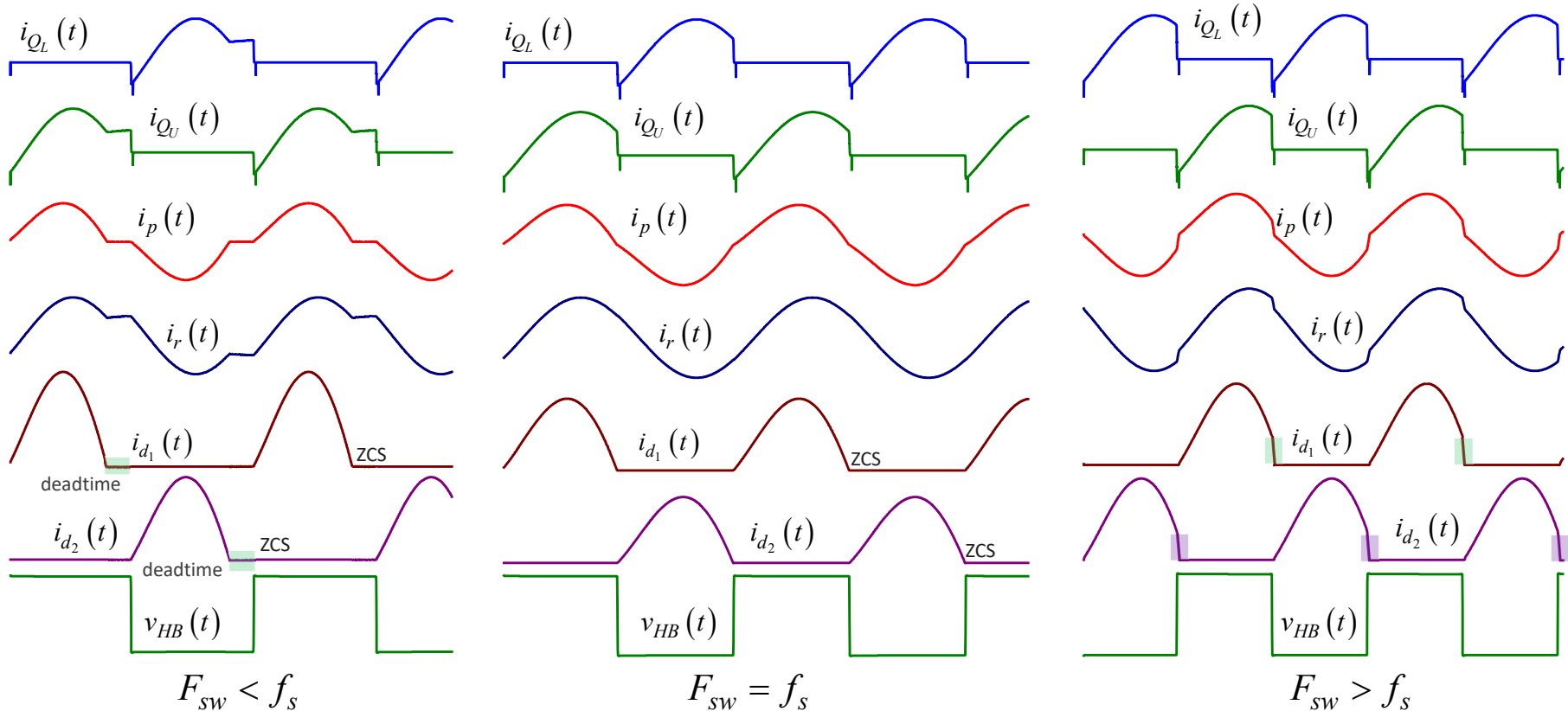

Ensuring Zero-Voltage Switching

- The deadtime duration must be sufficiently long to discharge parasitics
- ✓ Select primary inductance so that magnetizing current ensures ZVS at the highest F_{sw}

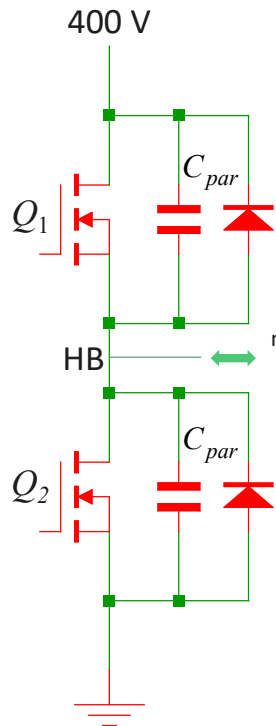

Condition for ZVS:

$$\frac{1}{2}(L_m + L_r) I_{m,peak}^2 \geq \frac{1}{2}(2C_{par}) V_{in}^2$$

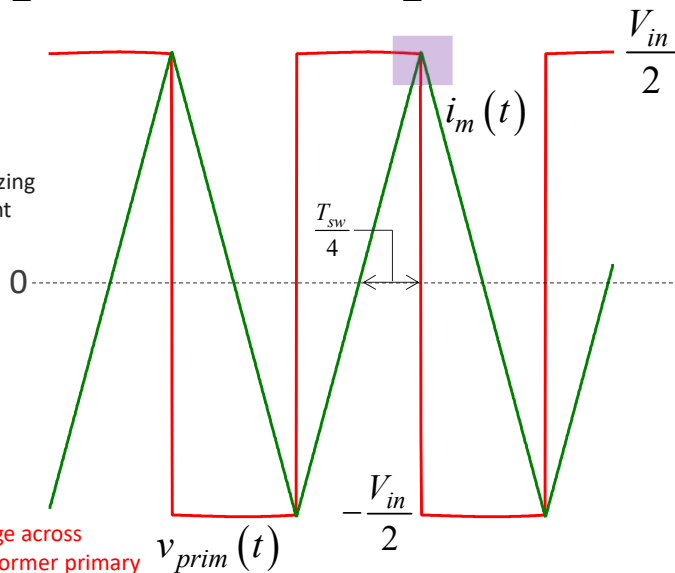

$$t_{DT} = \frac{V_{in} \cdot 2C_{par}}{I_m}$$

$$I_m \approx \frac{V_{in}}{2L_m} \frac{1}{4F_{sw}}$$

$$t_{DT} = V_{in} \cdot 2C_{par} \cdot \frac{8L_m F_{sw}}{V_{in}}$$

$$t_{DT} \geq 16 \cdot C_{par} L_m F_{sw}$$

The Right DeadTime for ZVS Conditions

- Calibrate deadtime to minimize body diode conduction time whilst ensuring ZVS

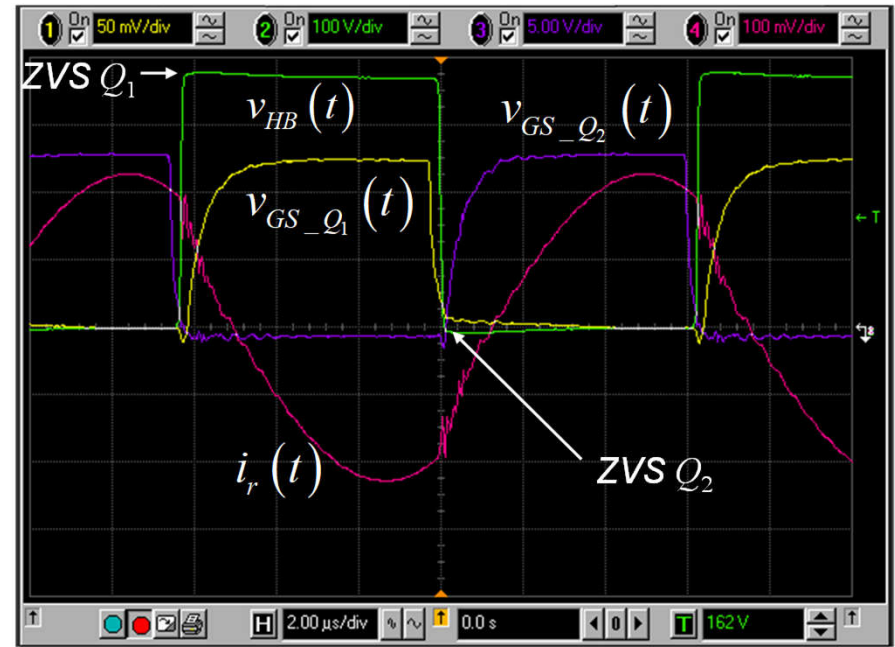
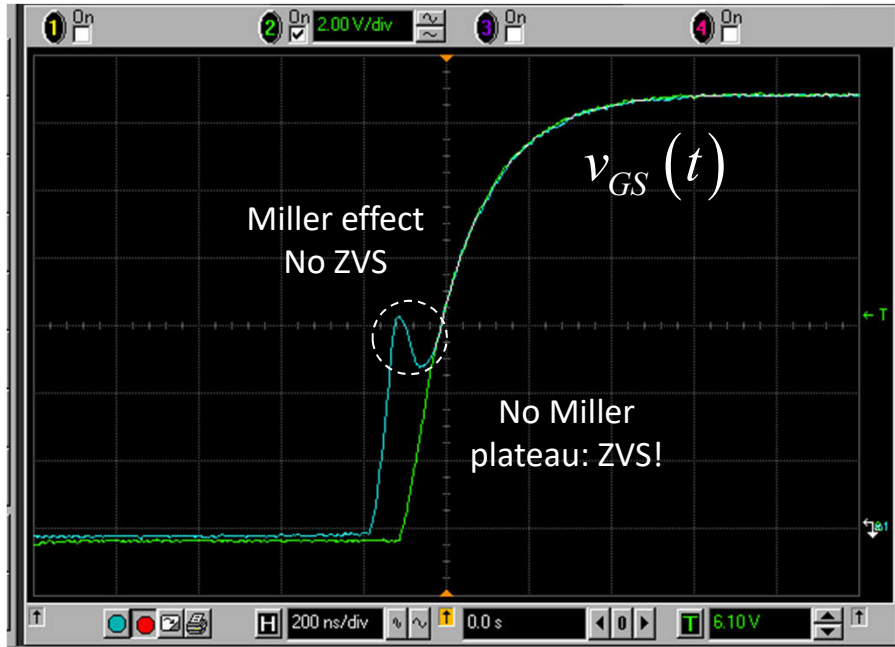

ZVS gets rid of the Miller plateau and further minimizes drive losses

SIMPLIS can simulate GaN Transistors

- Adding GaN transistors to the schematic capture is an easy process

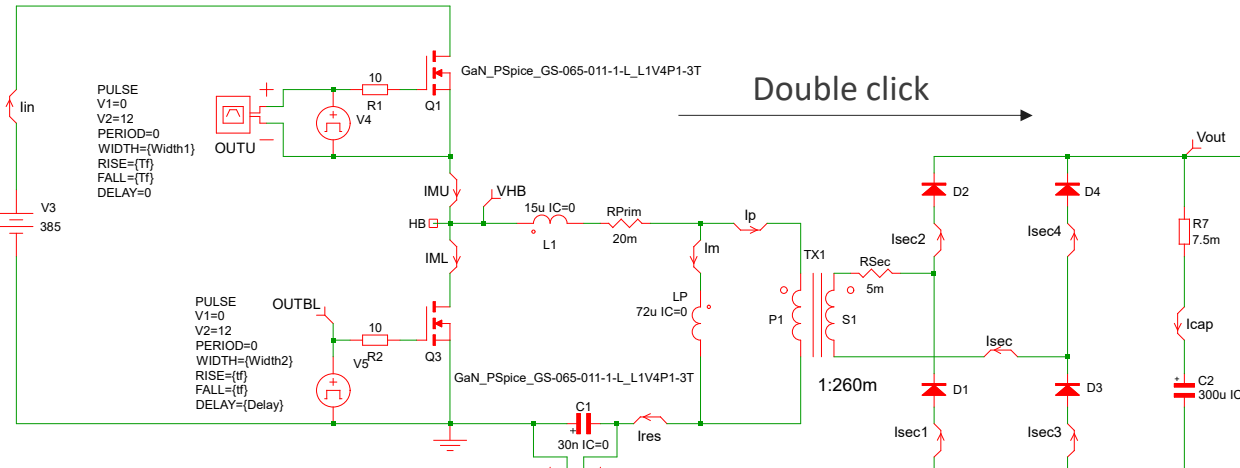

Double click

Extract MOSFET: Q1 Parameters

Description
The SIMPLIS MOSFET model can be extracted from an installed SPICE model, or can be manually entered by clicking on the User-defined button.

Model type
 Extracted
 User-defined

Model extraction test conditions

SPICE Model: .1V4P1-3T [Select...]

Drain to source voltage: 400 V

Gate drive voltage: 5 V

Drain current: 10 A

Model temperature: 25 °C

Model level: 2

Limit maximum off resistance
Maximum off resistance: 100Meg Ω

Show extracted PWL waveforms

[Extract] [Cancel] [Help]

```
*
.VAR Fs=250k ; select frequency
.VAR DT=50n ; select deadtime
.VAR DC=0.5 ; select duty ratio
.VAR tf=1p
.VAR tr=1p
*
.VAR Ts=(1/Fs)
.VAR Width1={DC*Ts-DT}
.VAR Width2={Ts*(1-DC)-DT}
.VAR Delay={Width1+DT}
*
```

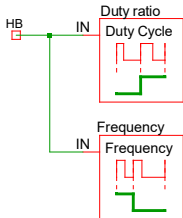

Simulation confirms ZVS with a Reduced Dead Time

- A smaller C_{oss} for the GaN leads to a lower magnetizing current for improved efficiency

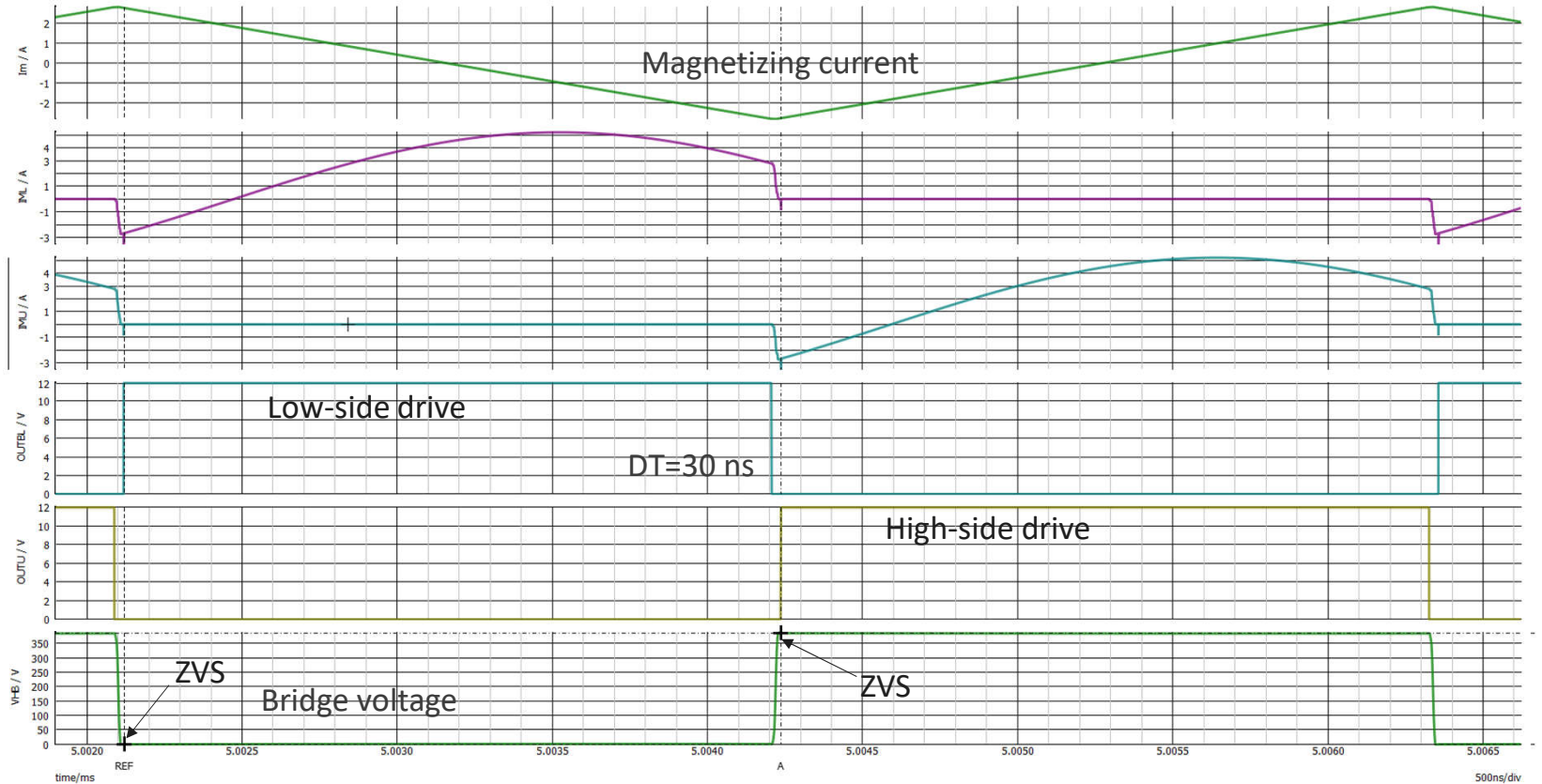

Agenda

- Hard and Soft Switching
- What is an LLC Converter?
- Controlling the Switching Frequency
- **Closing the Loop**
- Charge-Controlled Operation I
- Charge-Controlled Operation II
- Current-Mode Control
- Time-Shift Control
- An Overview of Available LLC Controllers

Controlling the LLC Converter

- We have seen that changing the switching frequency affects the output power
- If a regulation loop drives a voltage-controlled oscillator (VCO), output power is adjusted
- The frequency varies from a min value (high power) to a maximum high value (light load)

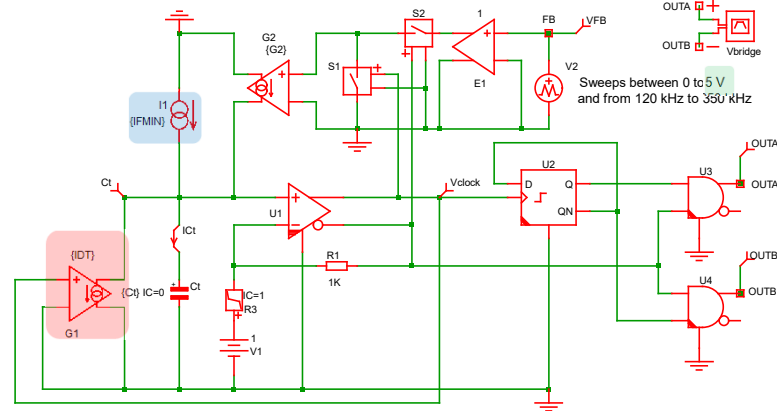
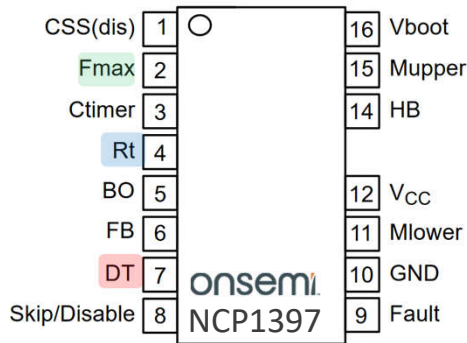

Small-signal VCO gain

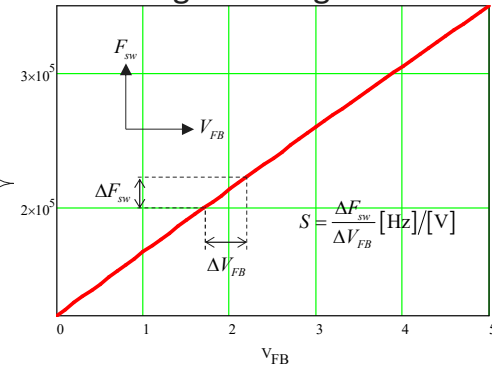

- A **dead time** is set to avoid shoot-through currents but also ensures ZVS operation

Transfer Function in Voltage-Mode Control

- There is no averaged model for the LLC because energy is transported by fundamental
- The control-to-output transfer function complicates proper compensation:
- ✓ The transfer function is a 3-pole system for $F_{sw} \neq F_o$ – dominant LF pole, one pole pair
- ✓ The transfer function becomes a 2-pole system when $F_{sw} \approx F_o$

$$H(s) \approx K_{vf} \frac{1 + \frac{s}{\omega_z}}{\left[1 + \frac{s}{Q\omega_o} + \left(\frac{s}{\omega_o} \right)^2 \right] \left(1 + \frac{s}{\omega_p} \right)}$$

- K_{vf} is a gain proportional to slope at the considered operating point on the voltage curve
- The quality factor Q and the double-pole beat frequency vary with operating conditions
- The low-frequency pole ω_p is linked to the output capacitance and also moves with operating conditions
- The output capacitor and its ESR contribute the zero ω_z



Compensating the LLC operated in voltage-mode is not a dinner party!

Simulating the LLC Converter

- A program like SIMPLIS lends itself perfectly for assessing the ac response of the LLC

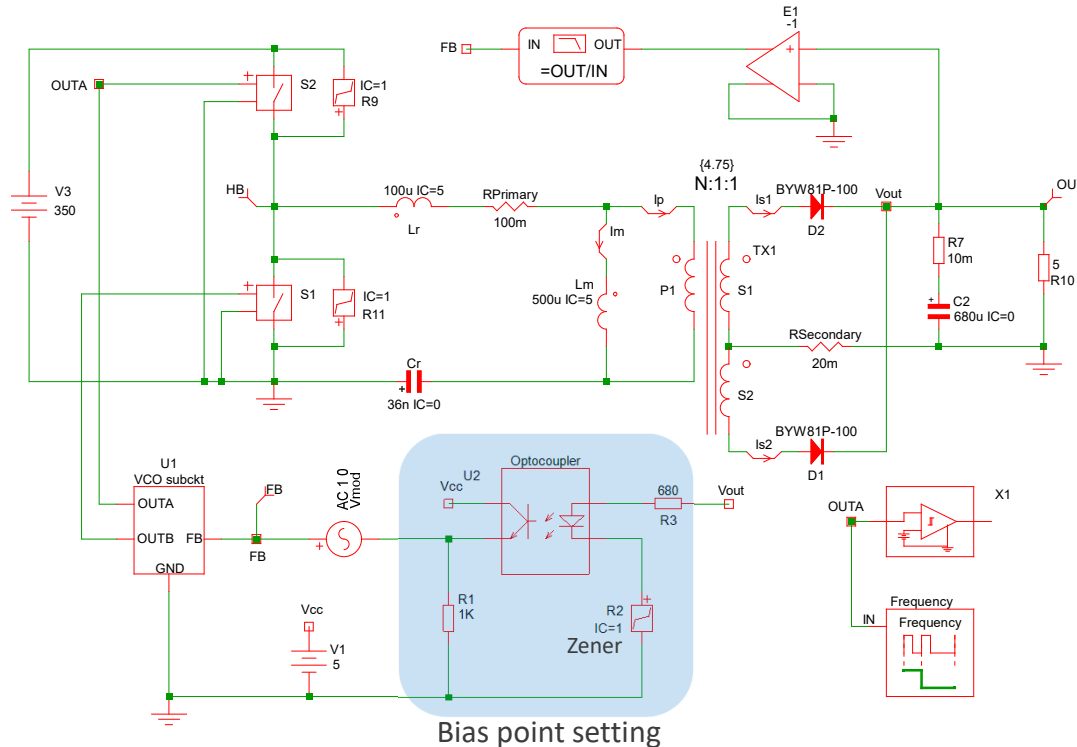

- A very simple setup is sufficient to obtain the transfer function
- The operating point is automatically set depending on V_{in} and P_{out}
- Frequency is recorded to see where the LLC stands at a given operating point.

$$L_T := 100\mu\text{H} \quad L_m := 500\mu\text{H} \quad C_T := 36\text{nF}$$

$$f_o := \frac{1}{2 \cdot \pi \cdot \sqrt{L_T \cdot C_T}} = 83.882\text{kHz}$$

$$f_{o2} := \frac{1}{2 \cdot \pi \cdot \sqrt{(L_T + L_m) \cdot C_T}} = 34.245\text{kHz}$$

Various Small-Signal Responses

- At a 350-V input voltage with two different loads, the shape changes considerably

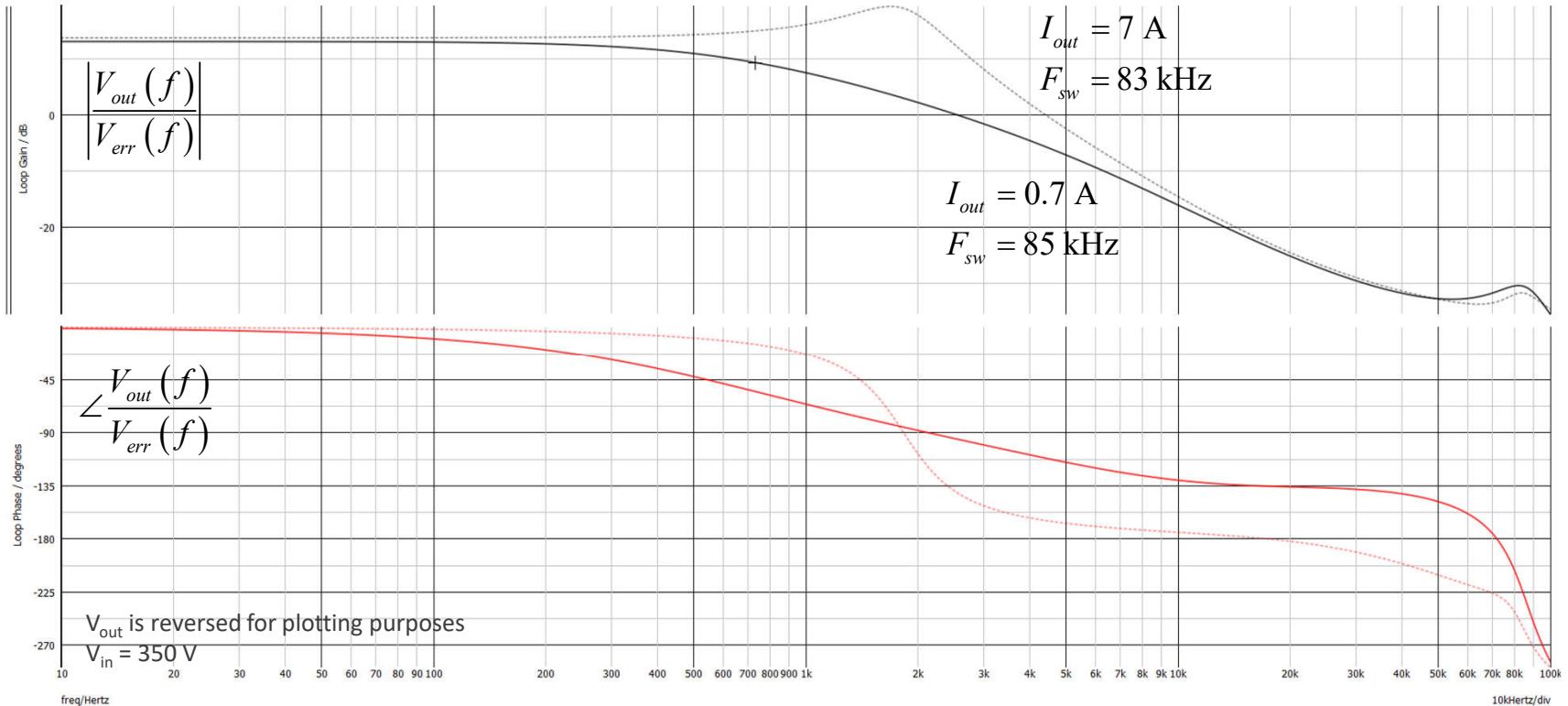

Control-to-Output Transfer Function – Variable Load

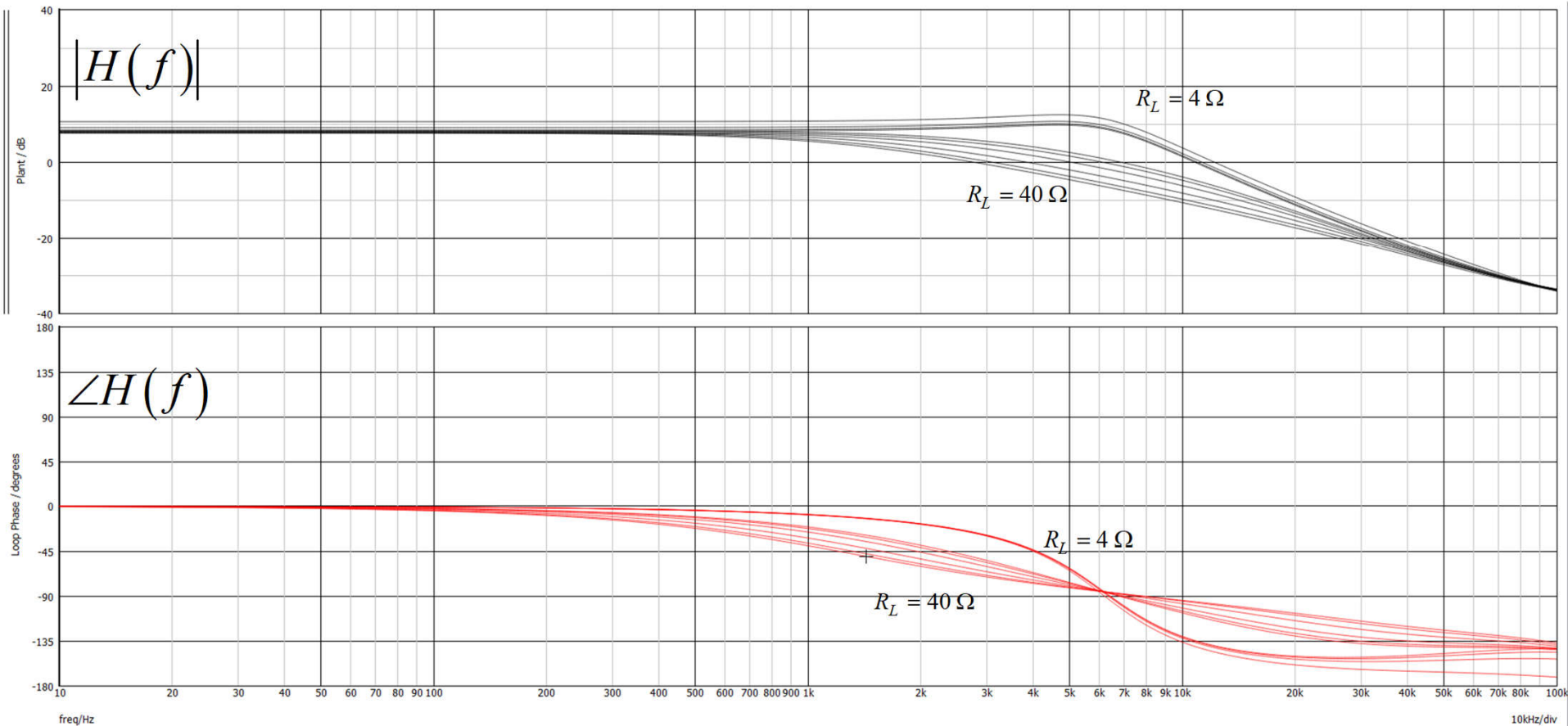

Control-to-Output Transfer Function – Variable Input

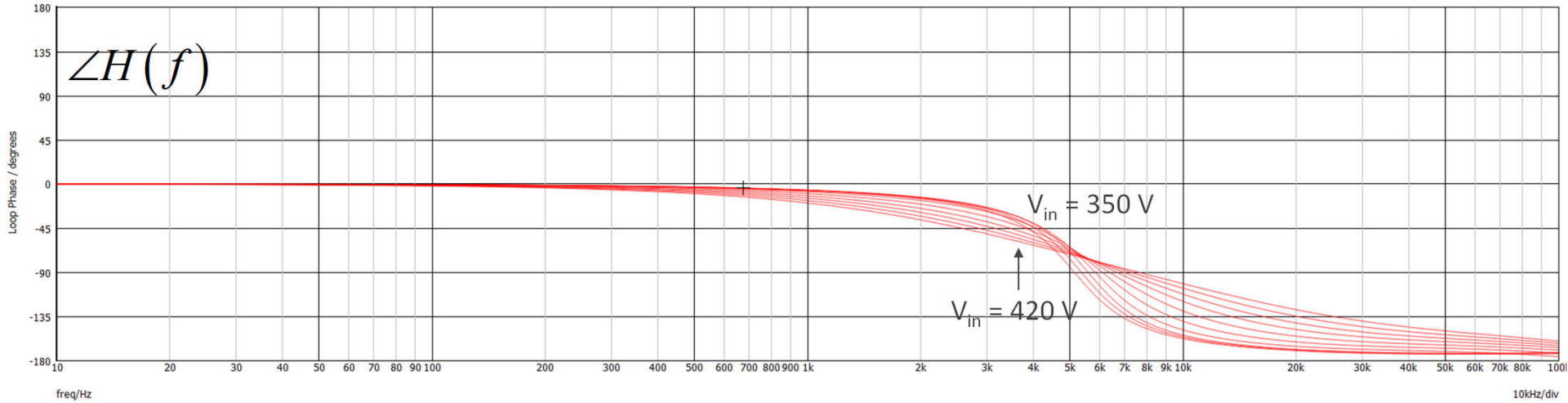
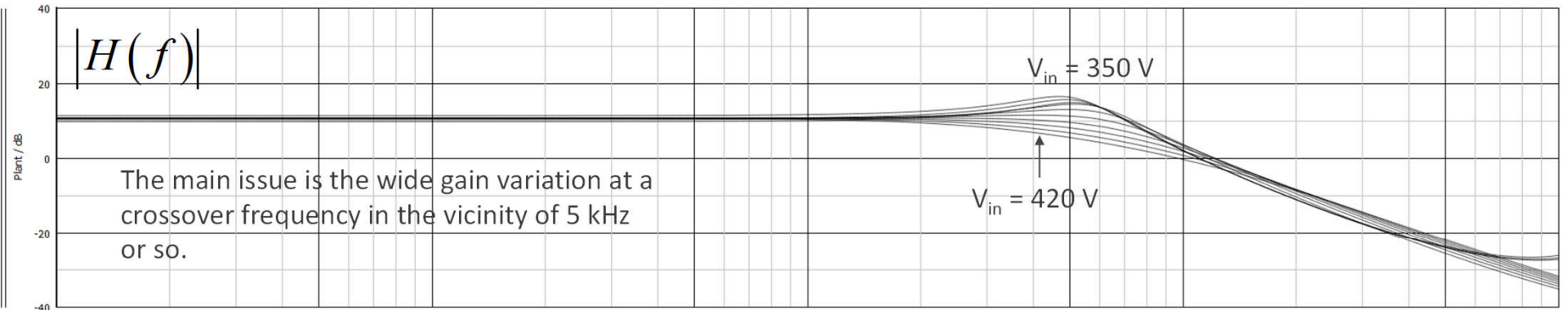

A Type 3 for Compensation

- Considering the deep phase lag, a type 3 compensator is needed
- The resonant peak occurs below 2 kHz implying a crossover at 4-5 kHz

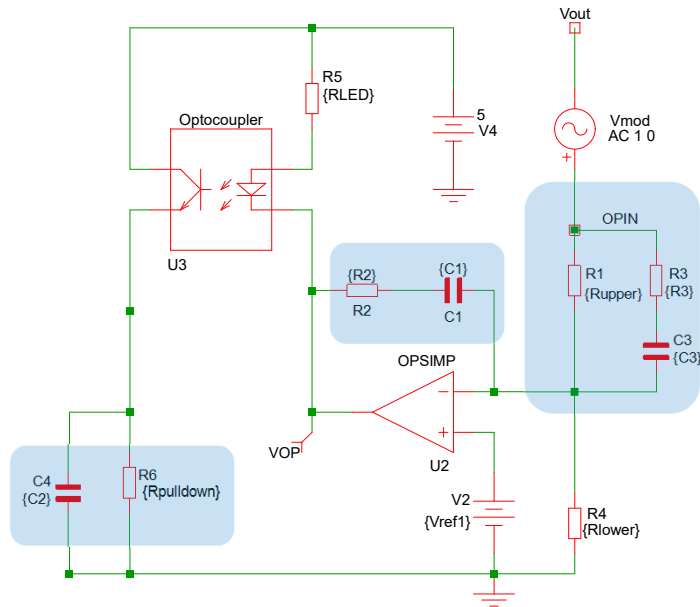

In the netlist



- *
- * Rupper = 9500
- * Rlower = 2500
- * R2 = 650.530552995995
- * R3 = 174.134419551935
- * C1 = 4.07756772168279e-07
- * C2 = 3.15387865941603e-08
- * C3 = 1.82795501890341e-08
- * Boost = 110
- * Fz1 = 600
- * Fz2 = 900
- * Fp1 = 8357.24400717011
- * Fp2 = 50000
- *

- SIMPLIS automates the poles-zeroes positions and components values

Always Check the Operating Point!

- The operating point will tell you if the converter regulates correctly
- It is important to check this point otherwise the ac analysis can be useless

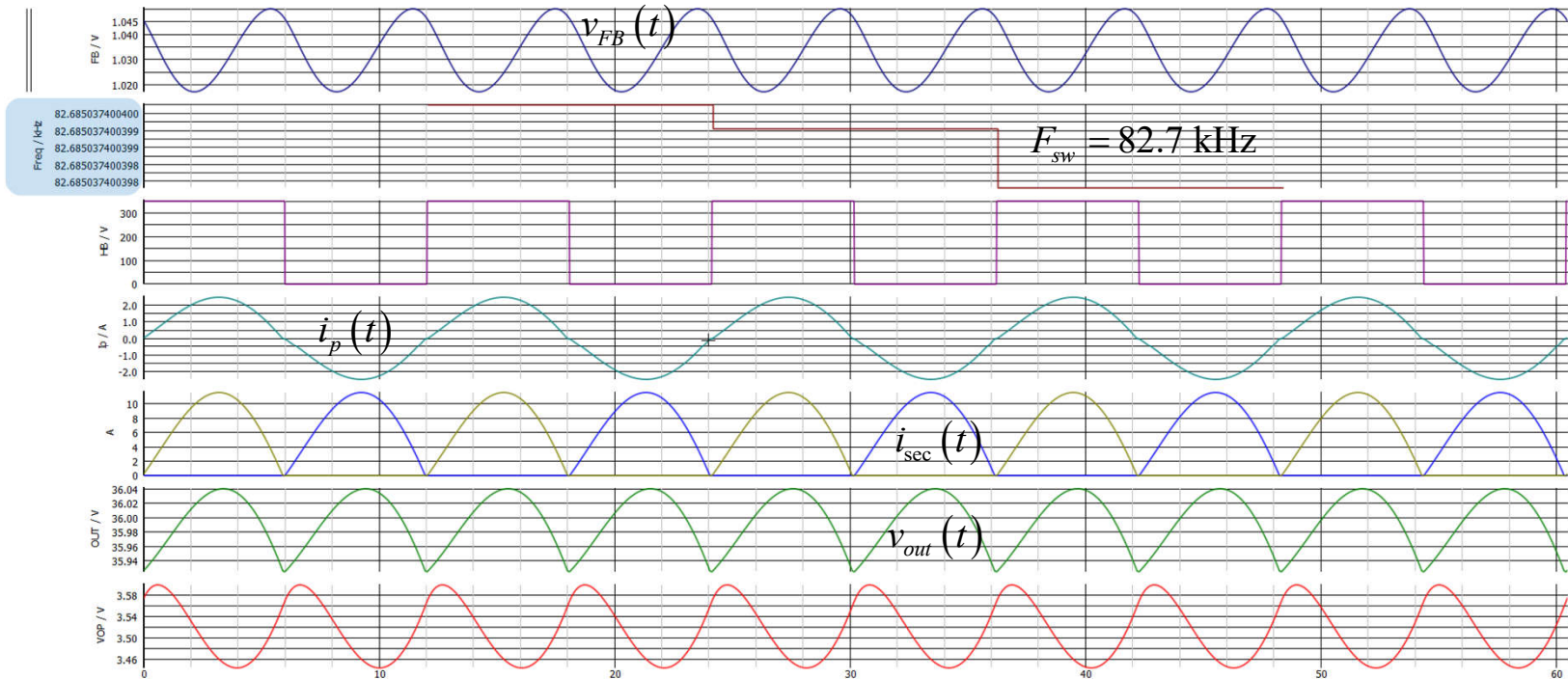

Good Compensation at a 350-V Input Voltage

- The simulation reveals a good loop gain meeting the wanted crossover and phase margin

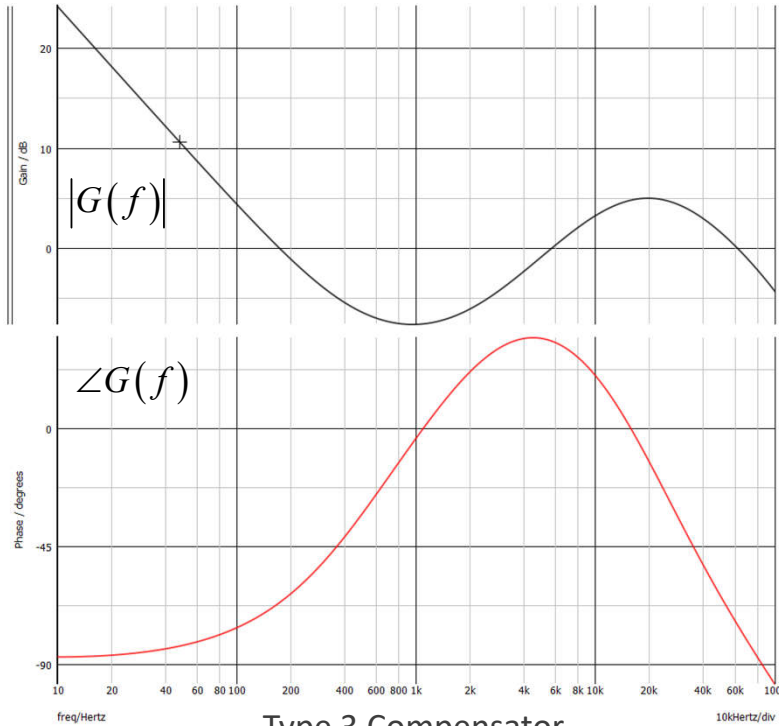

Type 3 Compensator

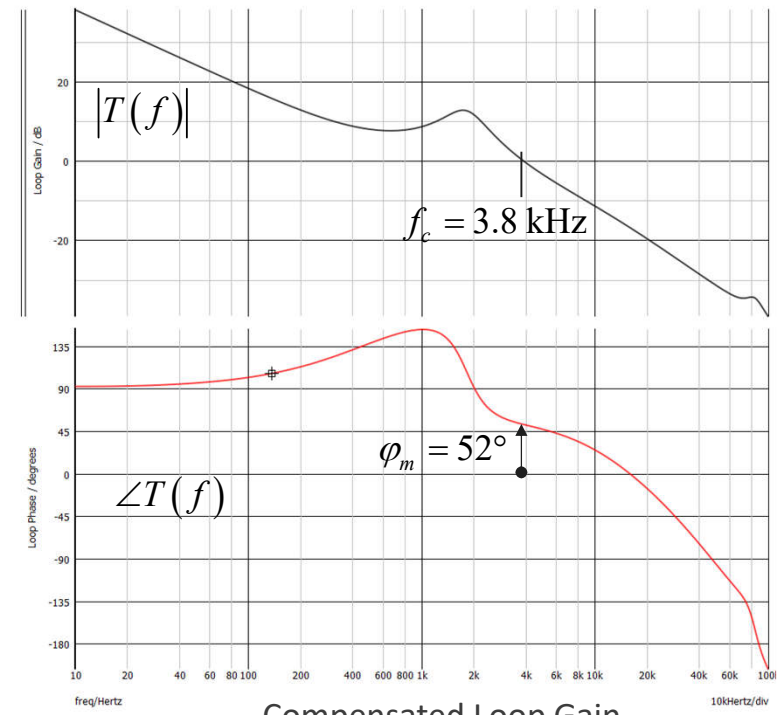

Compensated Loop Gain

Simulating the Entire Converter

- The simulation reveals a good loop gain meeting the wanted crossover and phase margin

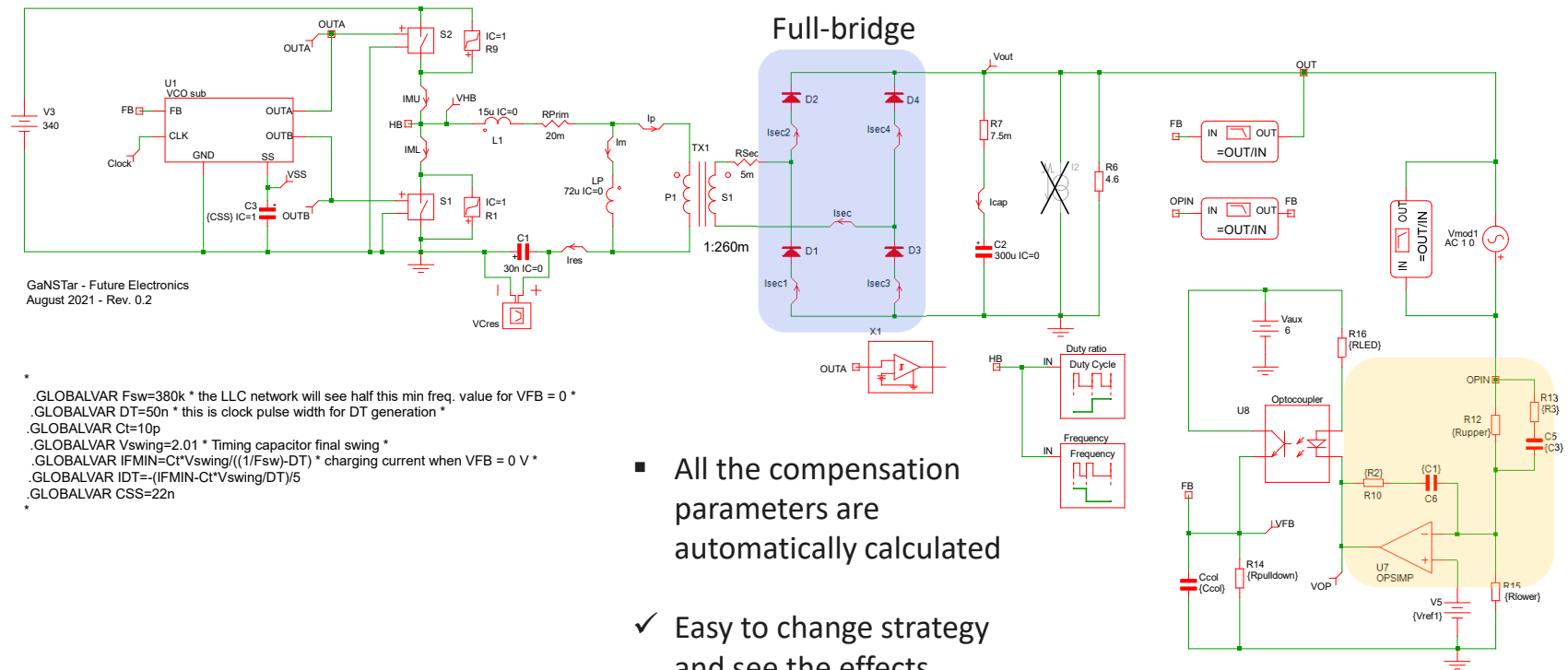

Large Variations of Loop Gain

- Changing operating conditions affect crossover and phase margin

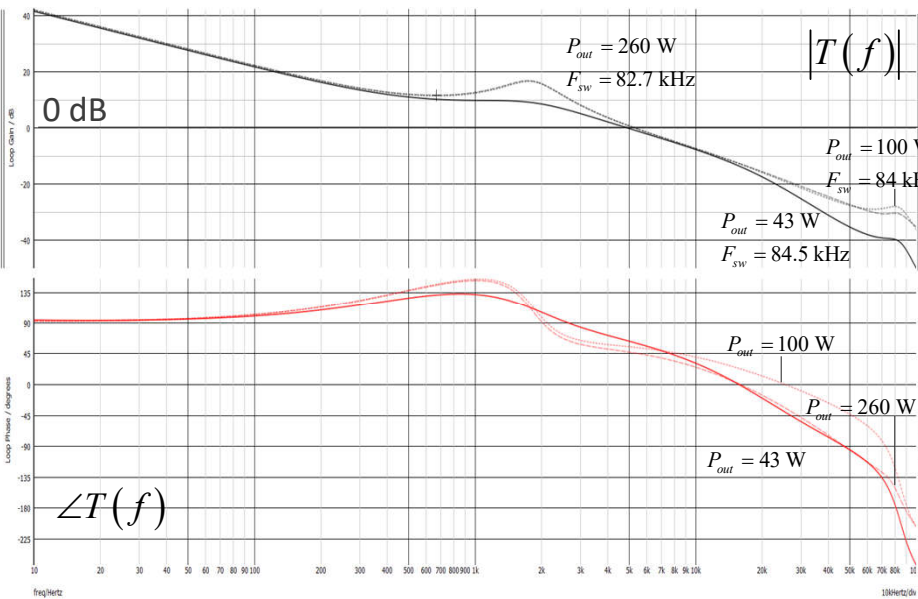

Low-line operations, $V_{in} = 350 \text{ V dc}$

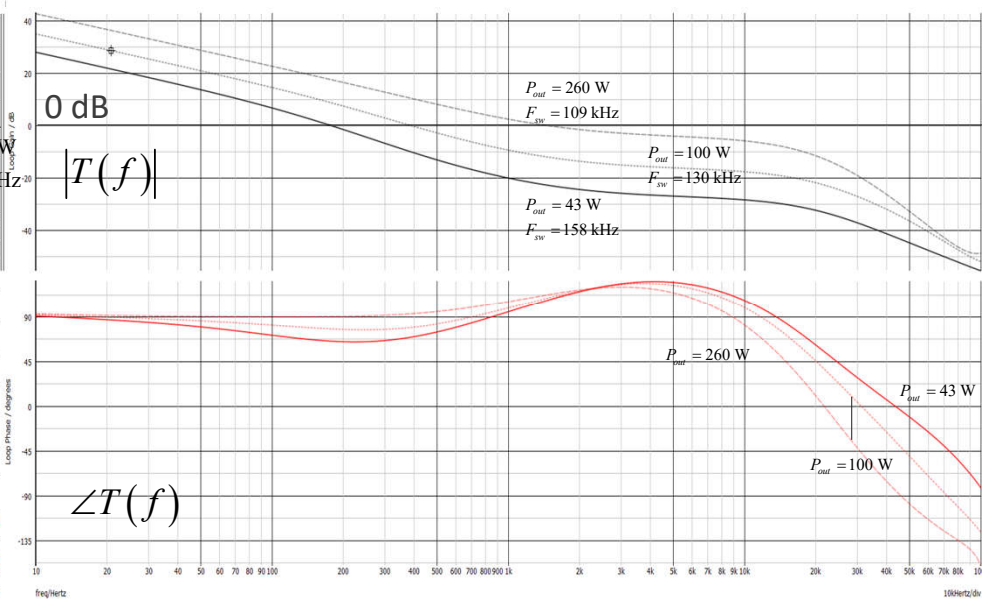

High-line operations, $V_{in} = 420 \text{ V dc}$

- At low line, frequency variations are moderate, operations close to resonance
- At high line, frequency variations are large, operations above resonance

Closed-Loop Operation with Analogue Compensation

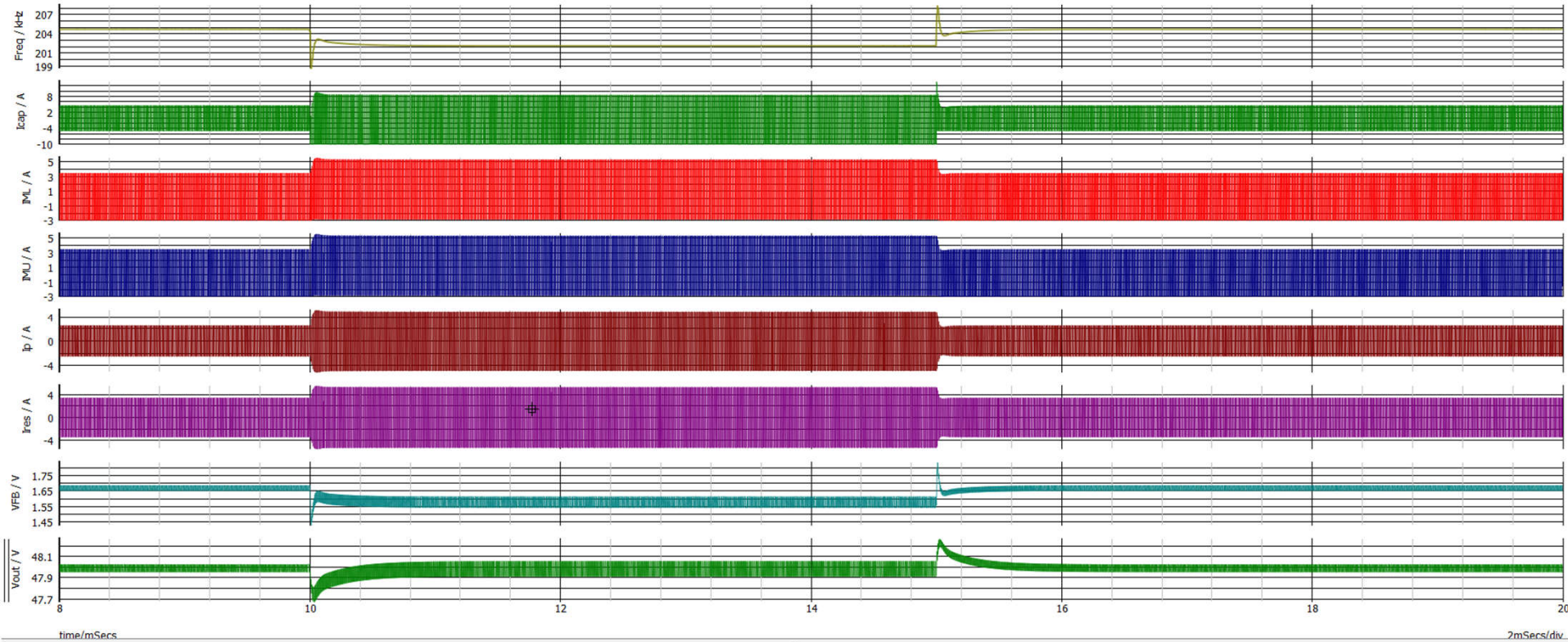

Transient response at $V_{in} = 340$ V and P_{out} stepped from 240 W to 480 W with a 1-A/μs slope

Combining an Analogue Front-End with Digital Control

- A TL431 will convey the secondary-side voltage to the non-isolated primary

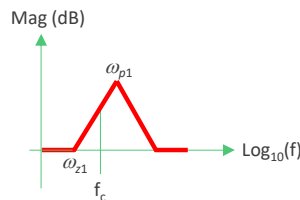
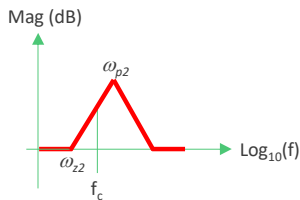
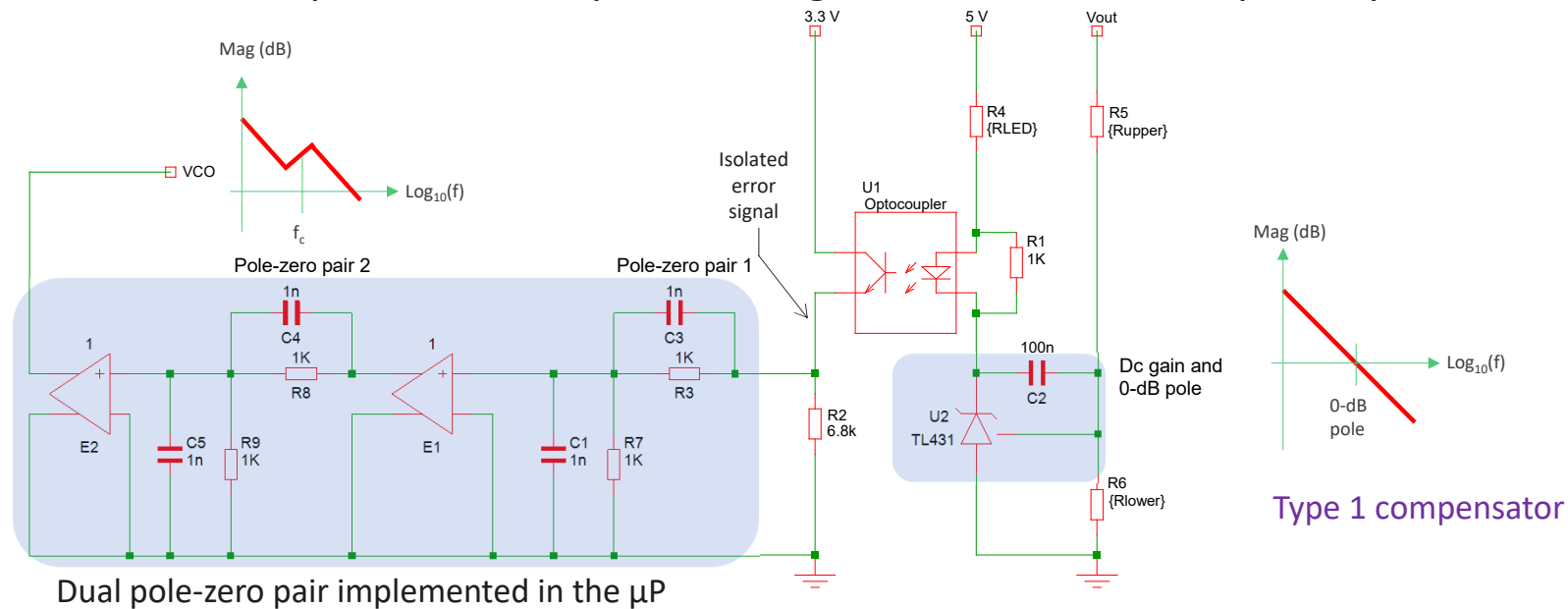

- This is the general architecture combining the secondary-side integrator featuring the error amplifier and the 2 zero/2 pole filter located in the primary side. This second section will be digitally implemented.

SIMatrix can Evaluate the Hybrid-Digital Configuration

- The adopted solution combines an analogue front-end with a digital compensator

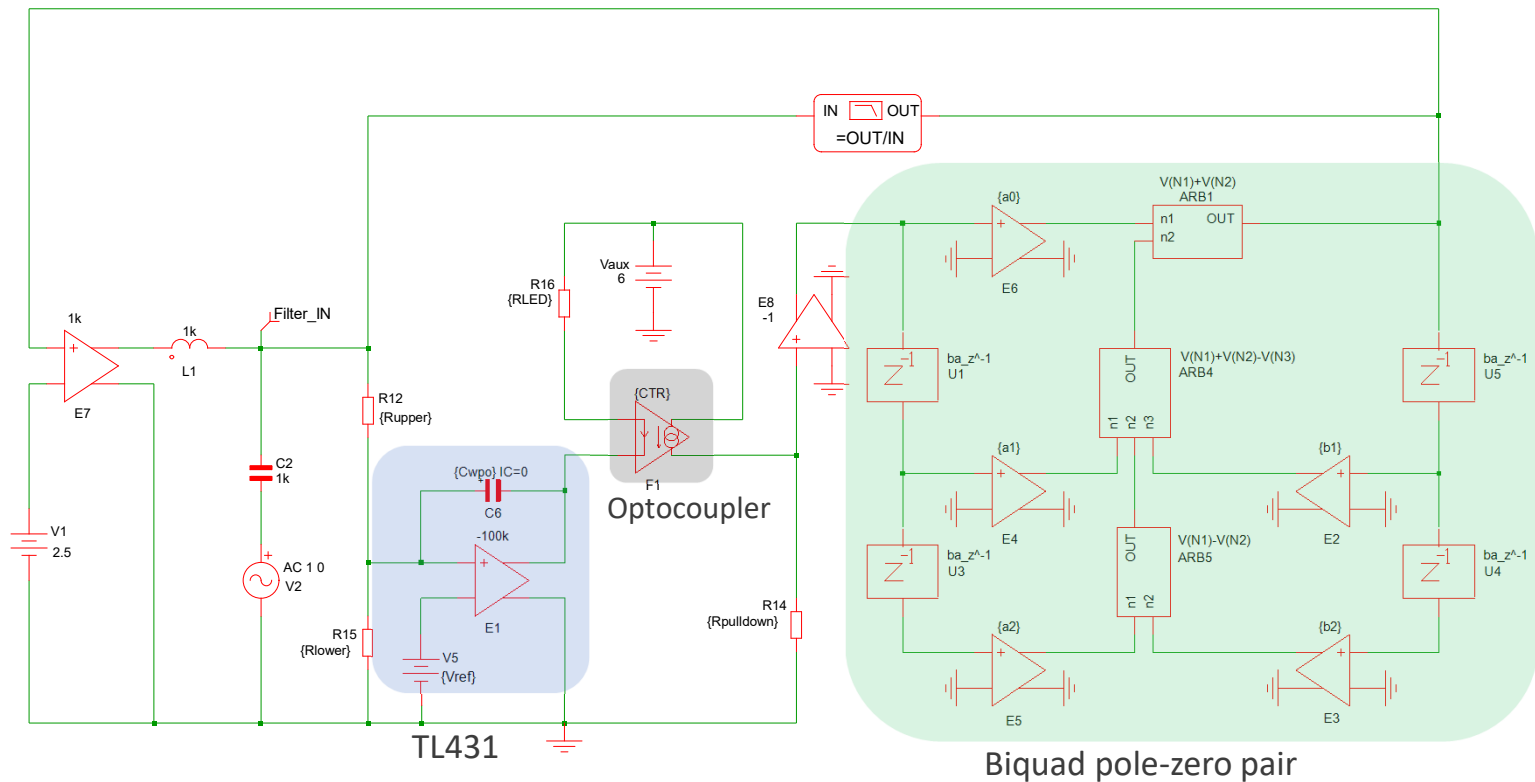

The Filter Response Changes with Sampling Frequency

- The combined response is that of a type 3 compensator as expected

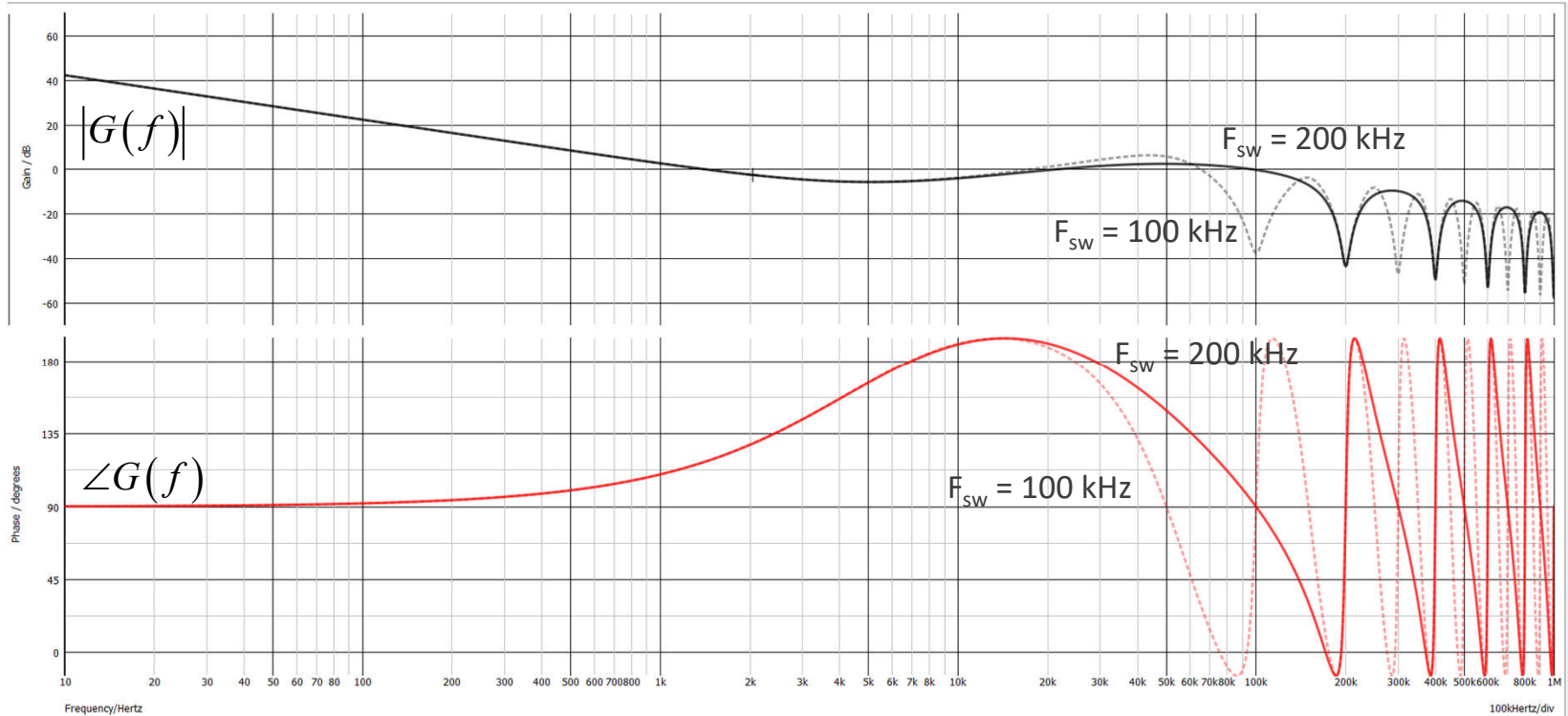

Typical Response at $V_{in} = 380\text{ V}$

- The transient test at the minimum input voltage shows a stable output response

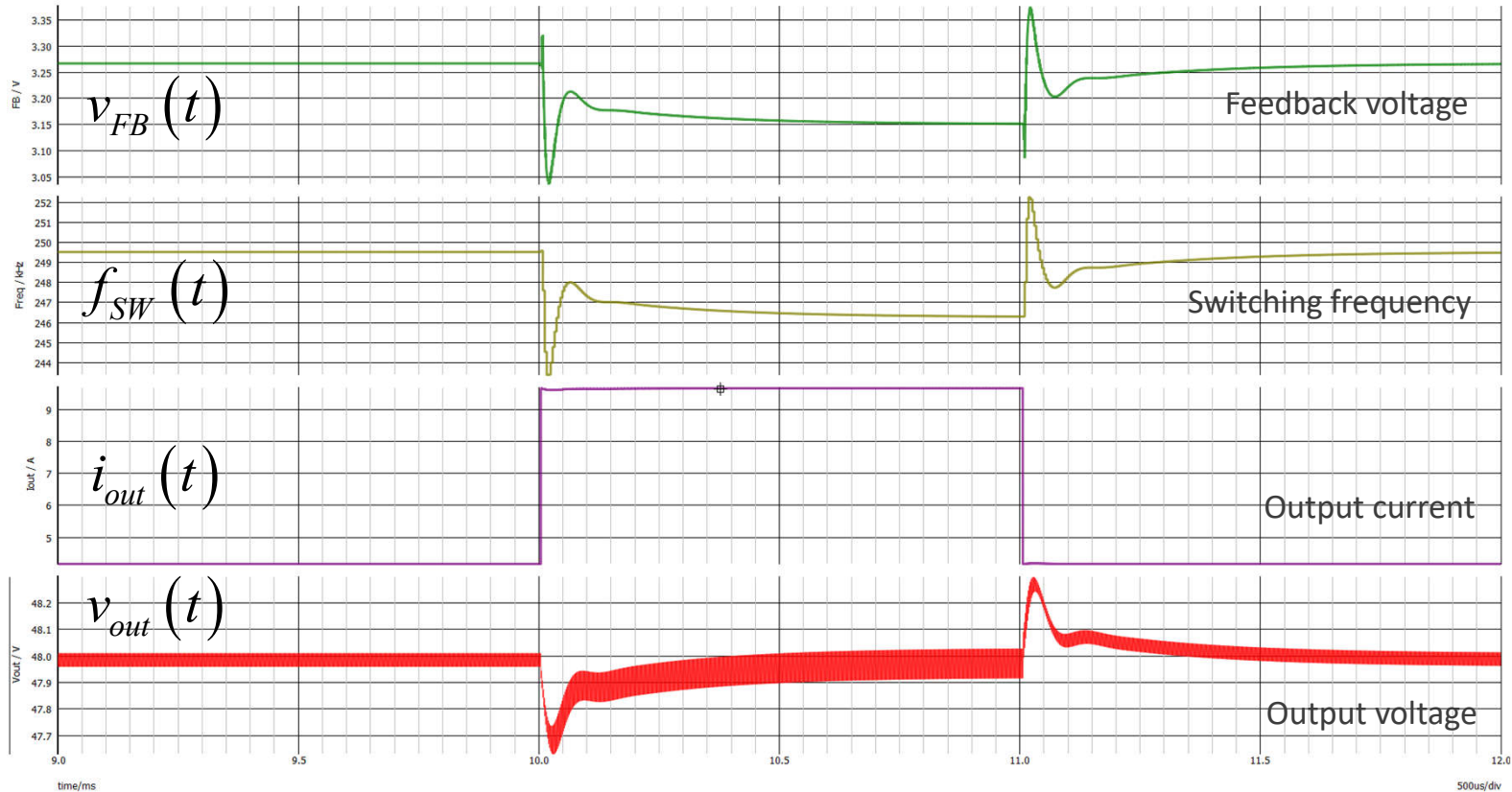

Agenda

- Hard and Soft Switching
- What is an LLC Converter?
- Controlling the Switching Frequency
- Closing the Loop
- **Charge-Controlled Operation I**
- Charge-Controlled Operation II
- Current-Mode Control
- Time-Shift Control
- An Overview of Available LLC Controllers

Charge Control Operations

- The voltage across the resonant capacitor is the integral of the resonant tank current

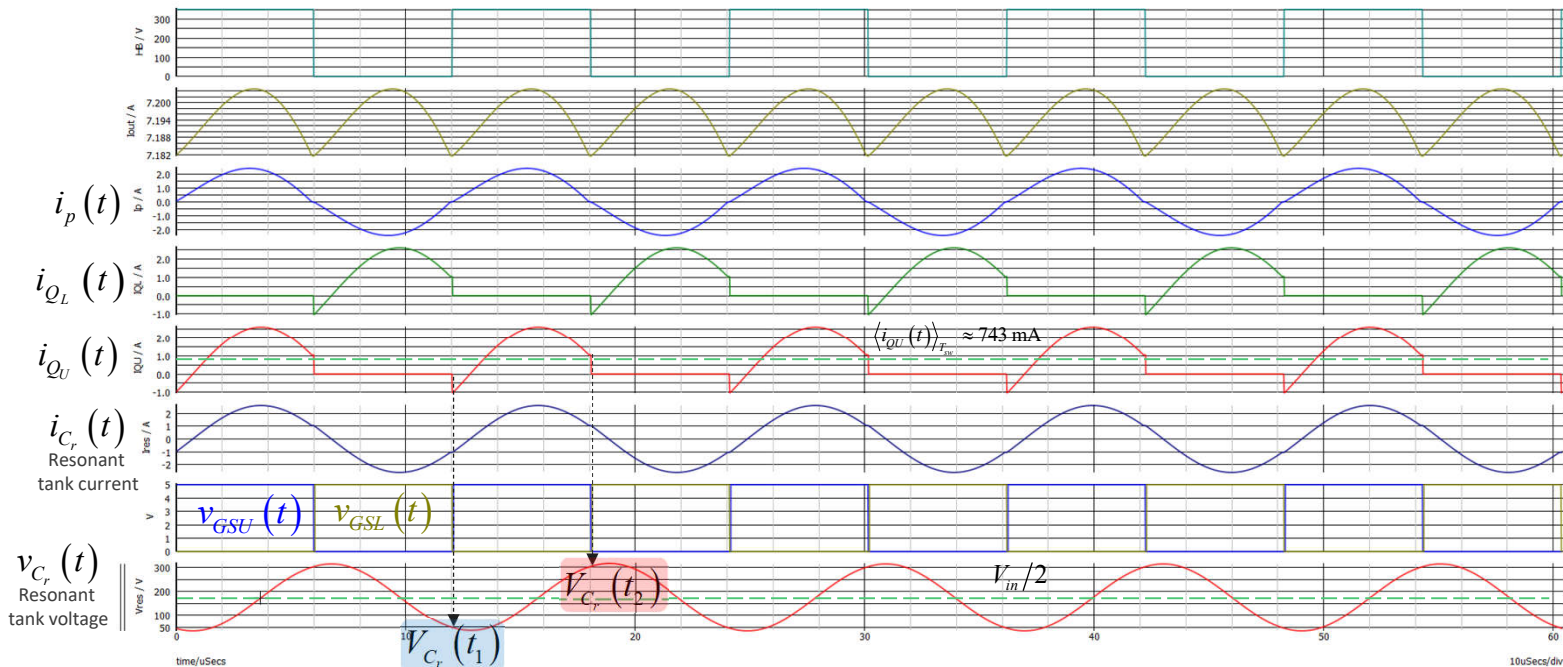

$$Q_{net} = Q_{neg} + Q_{pos}$$



$$Q_{net} = C_s [V_{C_r}(t_1) - V_{C_r}(t_2)]$$



$$P_{in} = Q_{net} F_{sw} V_{in}$$

- The net electric quantity can be calculated from the capacitor voltage at t_1 and t_2
- $P_{in} = 36n \times (302 - 46) \times 83k \times 350 \approx 268 \text{ W}$

Adjusting the Output Power

- In a half-bridge topology, the average voltage across the resonating capacitor is $\frac{V_{in}}{2}$
- Owing to symmetry of the waveform, we can define the two voltages

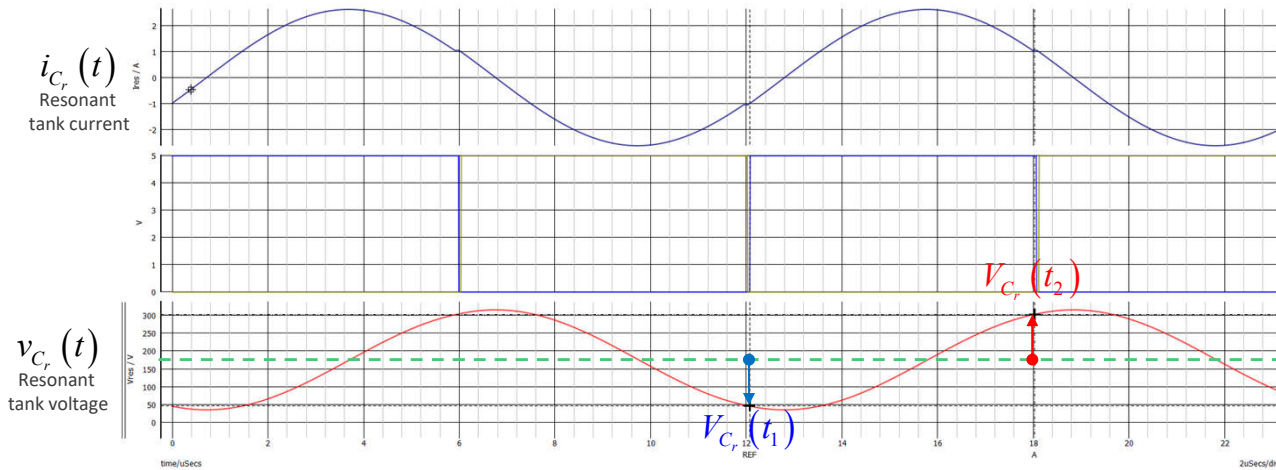

$$\frac{V_{in}}{2} - V_{C_r}(t_1) = V_{C_r}(t_2) - \frac{V_{in}}{2}$$

$$V_{C_r}(t_1) + V_{C_r}(t_2) = V_{in}$$

- The feedback loop can set the peak voltage and deduce the valley voltage

$$V_{C_r}(t_1) = k_{sen} V_{in} - V_{C_r}(t_2)$$

valley
peak

Practical Implementation with TEA2017

- NXP's combo controller implements a proprietary bang-bang charge control scheme

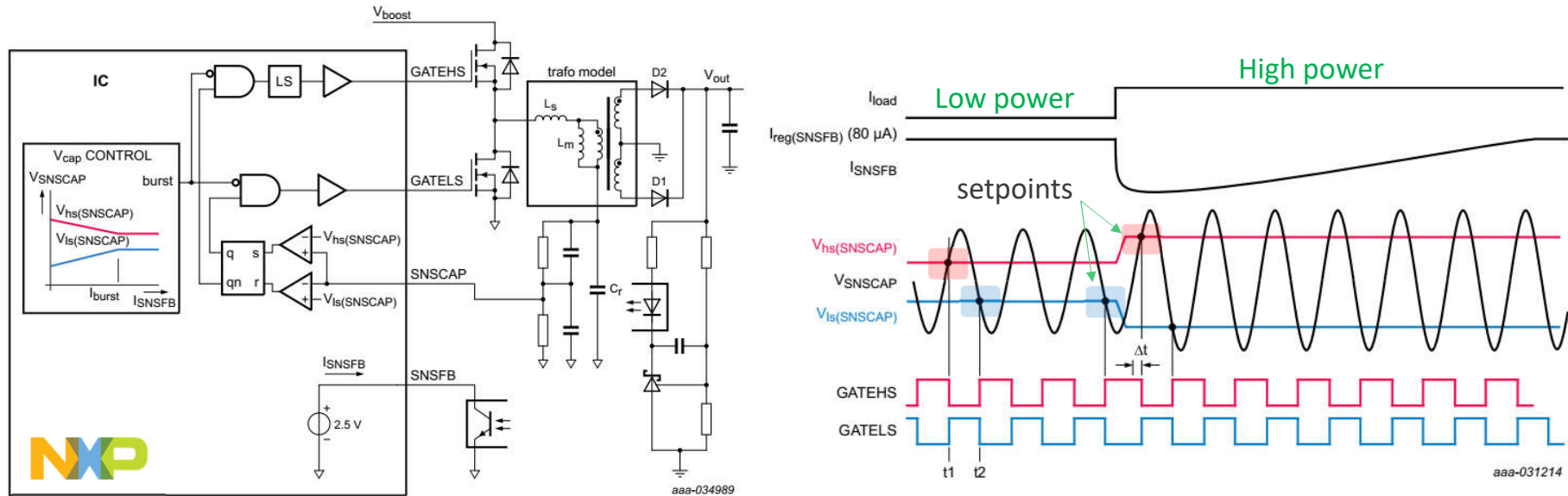

- Absorbing current from the feedback pin adjusts resonating peak voltage setpoints
- The optocoupler *average* current is regulated at 80 μA for best standby power

Modeling the Modulator Section

- A SIMPLIS model helps understand how setpoints are modulated in values

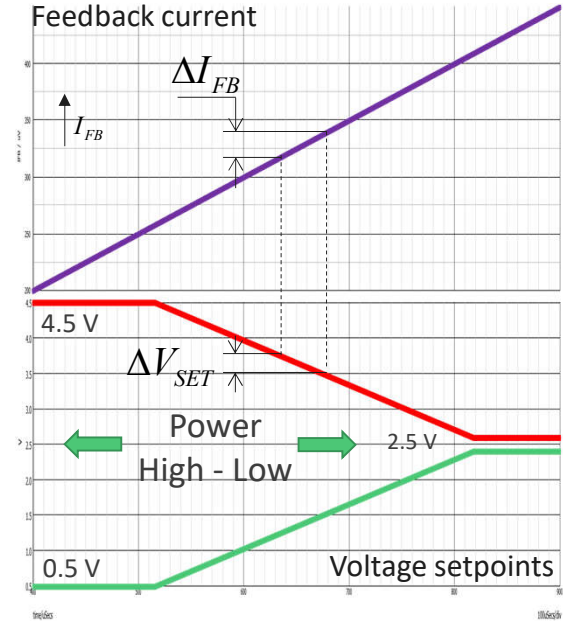
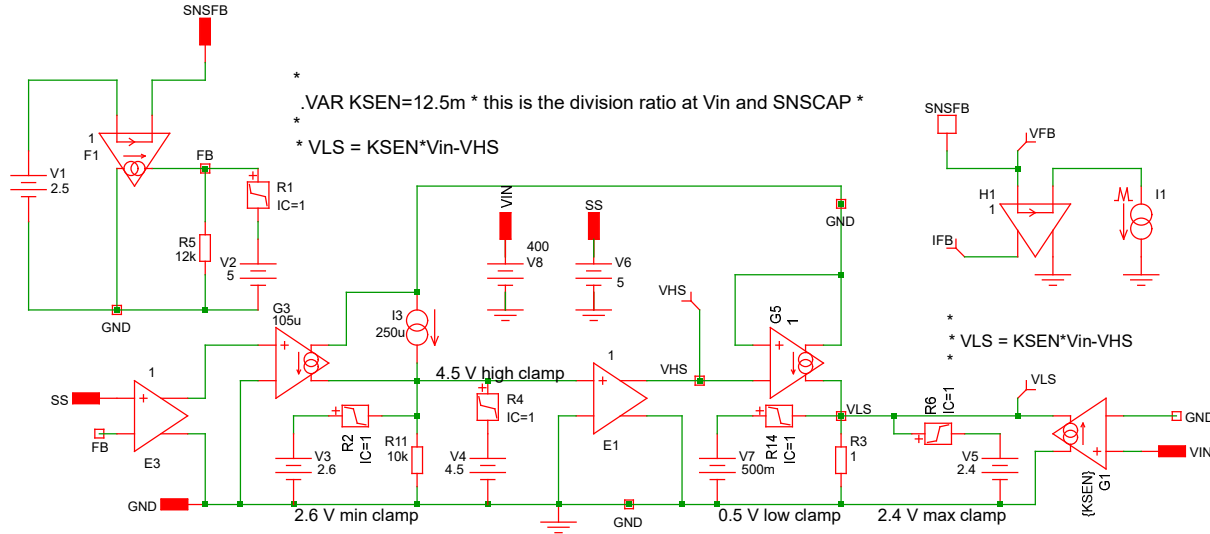

- The modulator imposes a small-signal gain

$$\rightarrow G = \frac{\Delta V_{SET}}{\Delta I_{FB}}$$

An Easier-to-Compensate Converter

- The charge control scheme simplifies the control-to-output transfer function

$$\frac{V_{out}(s)}{V_{inH}(s)} = H_0 \frac{1}{1 + \frac{s}{\omega_p}} \quad H_0 = \frac{V_{in} C_r F_{sw} k_{sen} R_L}{V_{out}} \quad \omega_p = \frac{1}{C_{out} R_L} \quad \omega_z = \frac{1}{r_C C_{out}}$$

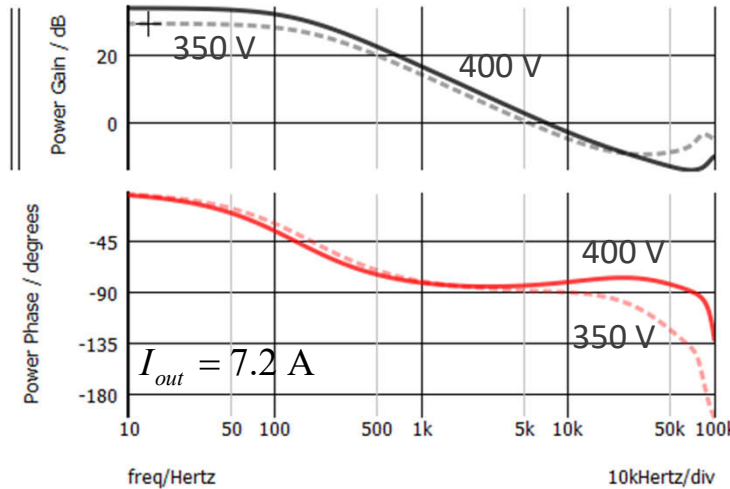

Power stage, different input voltages

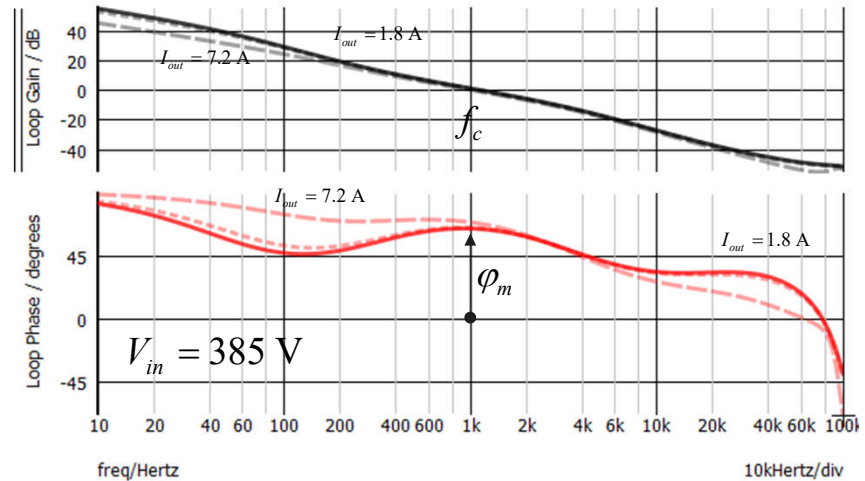

Loop gain at different output currents

A 12-V/50-A Demonstration Board

- Typical application of the TEA2017 in a 600-W demonstration board – UM11613

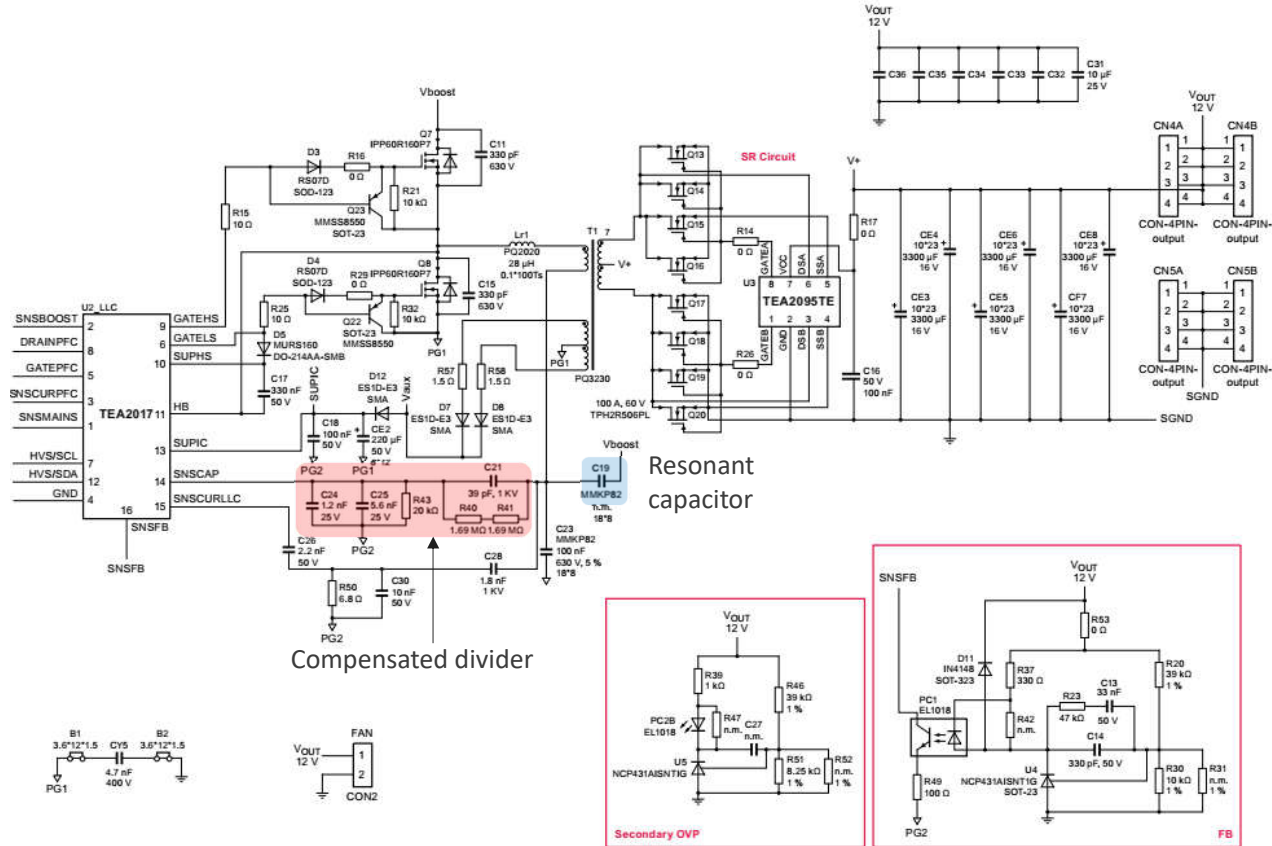

Agenda

- Hard and Soft Switching
- What is an LLC Converter?
- Controlling the Switching Frequency
- Closing the Loop
- Charge-Controlled Operation I
- **Charge-Controlled Operation II**
- Current-Mode Control
- Time-Shift Control
- An Overview of Available LLC Controllers

Integrating the Primary Current

- Fairchild – now onsemi – patented a technique based on charge control
- The resonating current is **integrated** and supplemented with an artificial ramp
- The resulting waveform is then classically compared with the **error voltage**

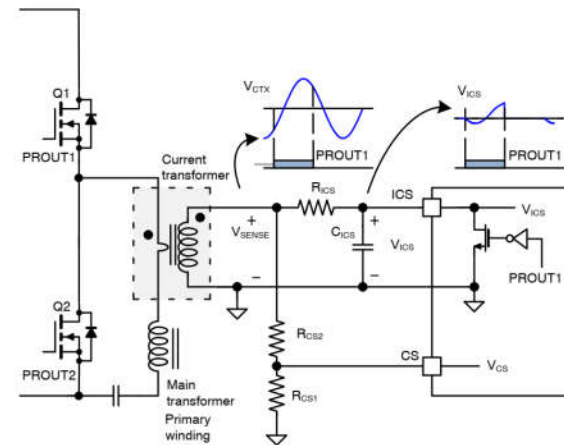
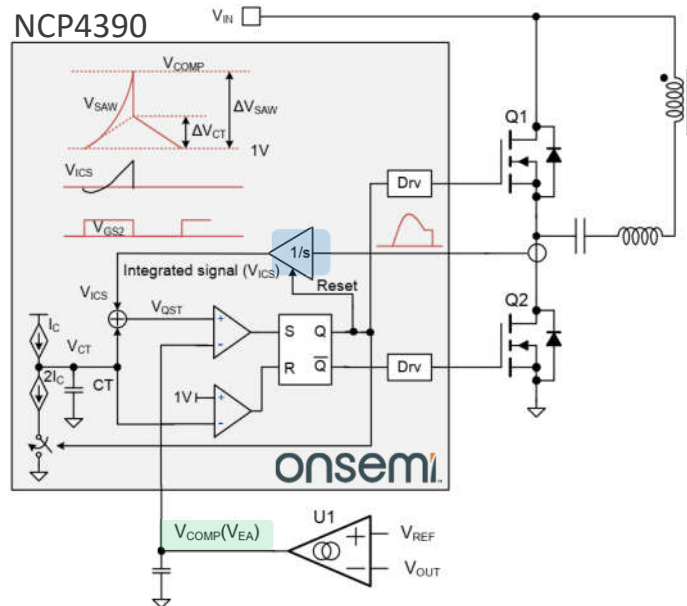

A current transformer provides the current information

Checking the Frequency Response

- It is possible to run a SIMPLIS simulation with the same LLC converter
- The converter is stabilized to crossover at 1 kHz with a 70° phase margin

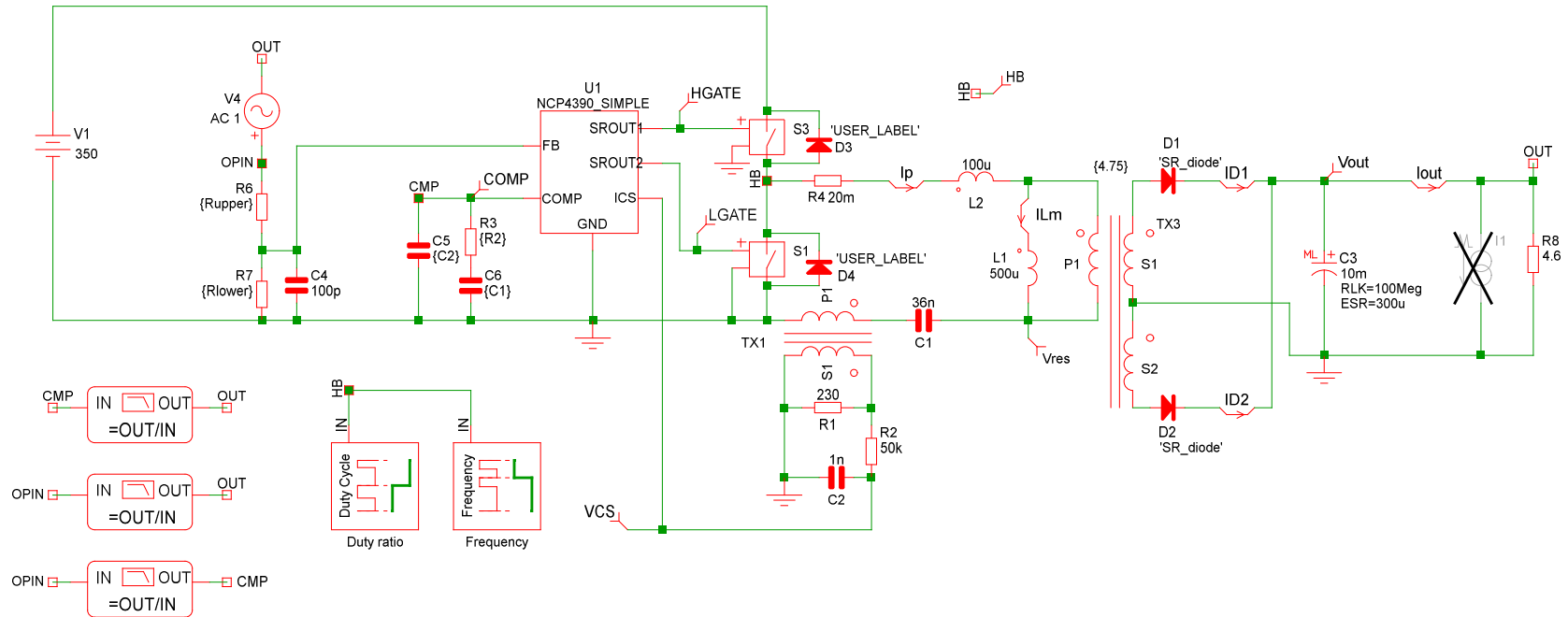

An Easier-to-Compensate Converter

- The frequency response, regardless of the input voltage or the load does not change
- Phase margin is comfortable and obtained with a simple type 2 compensator

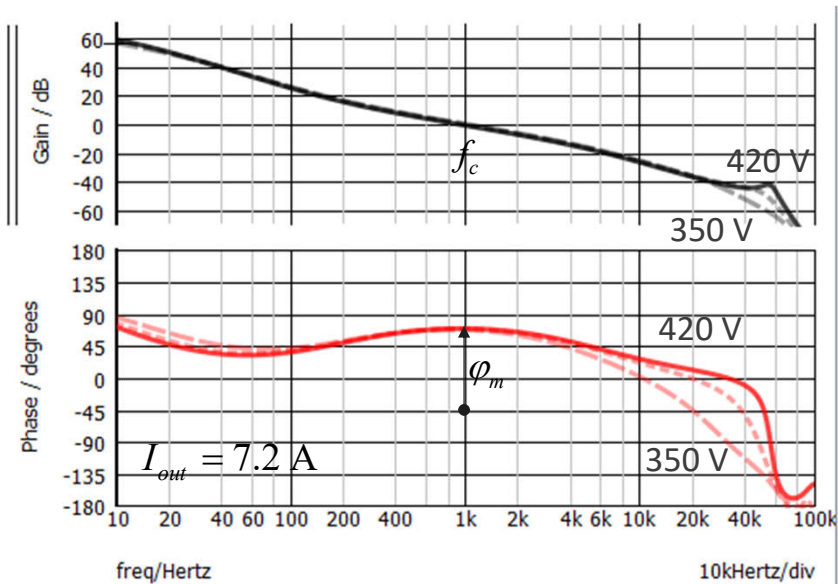

Loop gain, different input voltages

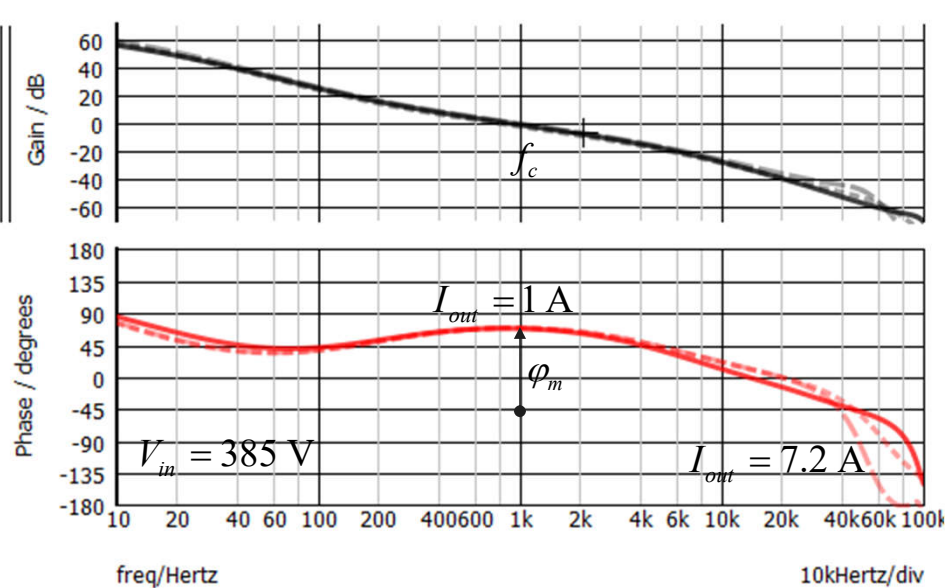

Loop gain, different output currents

High-Power Half- or Full-Bridge Control

- The controller is located in the secondary side for easier synchronous rectifiers control

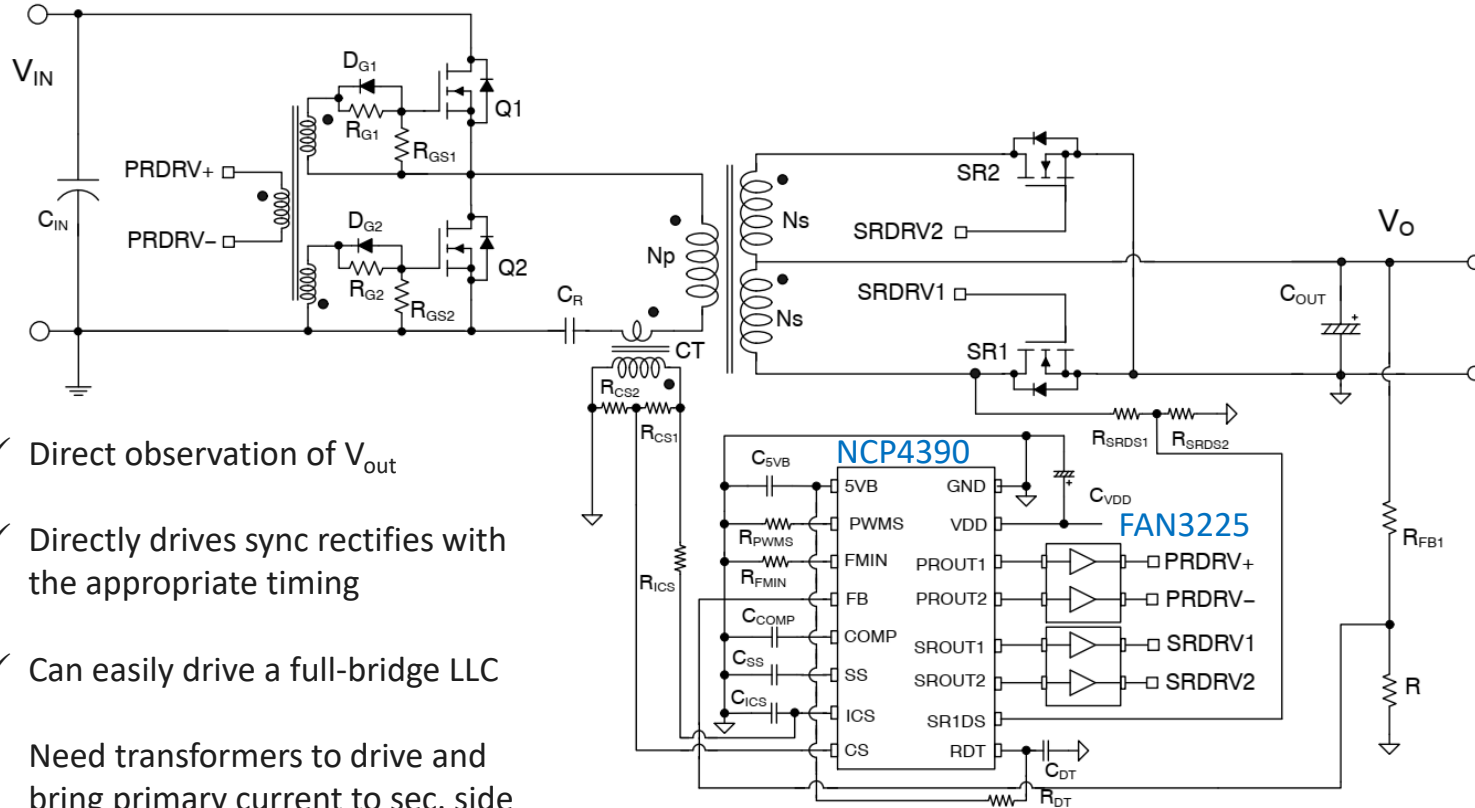

- ✓ Direct observation of V_{out}
- ✓ Directly drives sync rectifies with the appropriate timing
- ✓ Can easily drive a full-bridge LLC
- Need transformers to drive and bring primary current to sec. side

Agenda

- Hard and Soft Switching
- What is an LLC Converter?
- Controlling the Switching Frequency
- Closing the Loop
- Charge-Controlled Operation I
- Charge-Controlled Operation II
- **Current-Mode Control**
- Time-Shift Control
- An Overview of Available LLC Controllers

Current-Mode Control Operations

- The NCP13992 observes the resonating current integrated by capacitor C_r
- A cycle-by-cycle control adjusts the on-time to meet the peak current setpoint
- A digital core mirrors the on-time with a 10-ns resolution to drive the low-side switch

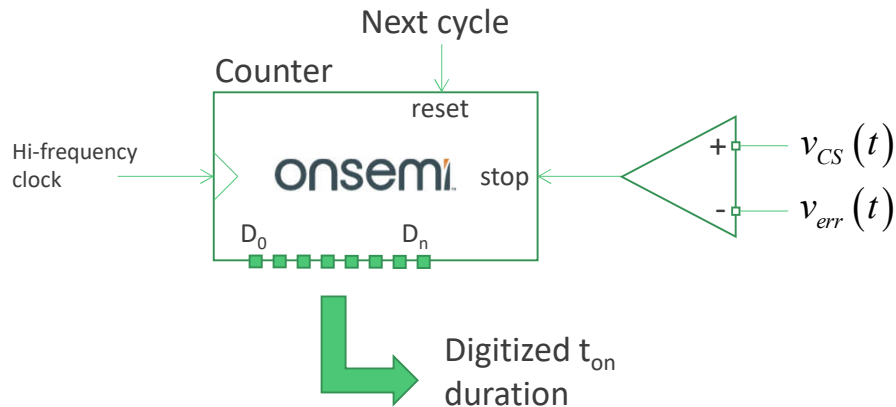
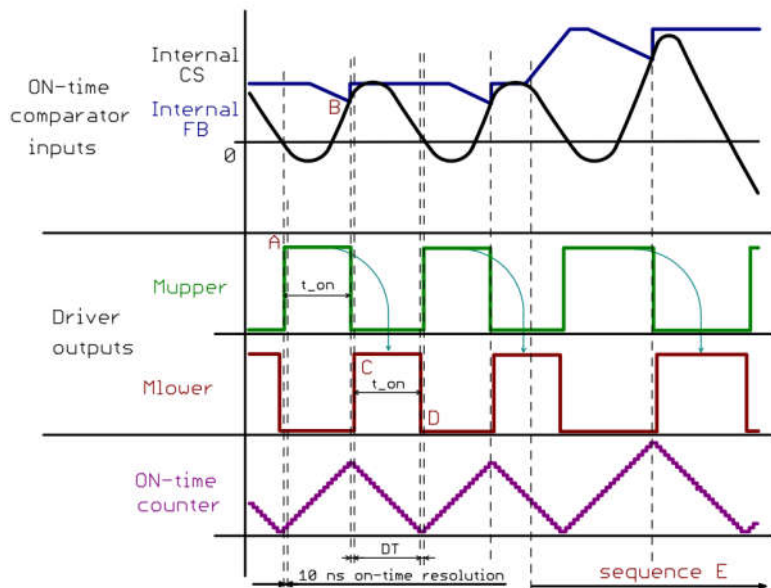

A digital core replicates t_{on} for an exact 50% operation

Ac Response of the Current-Mode-Controlled LLC

- It is possible to emulate the on-time replication via an analogue subcircuit
- Symmetry between timings is obtained with a simple capacitor-based ramp generator

- A type 2 compensator is sufficient
- Current reading requires a simple capacitive divider

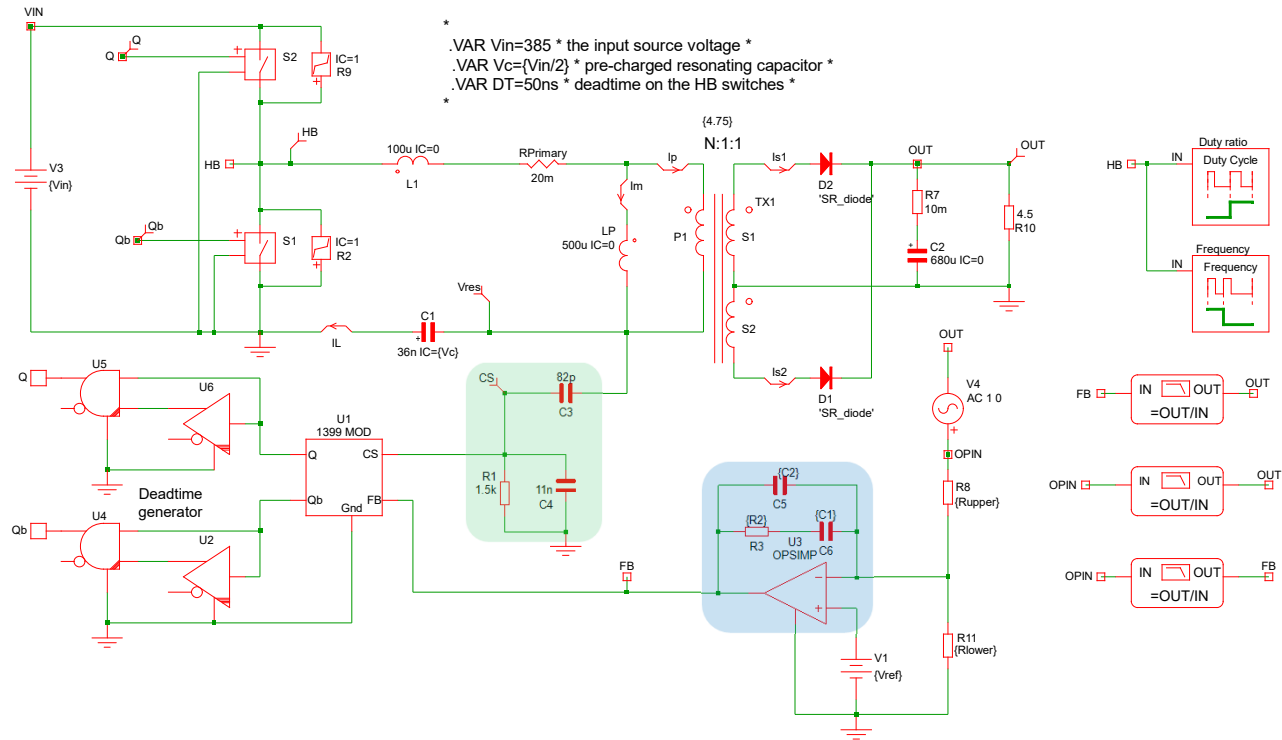

A Stable Response across all Operating Conditions

- The converter is compensated for a 1-kHz crossover frequency with a 60° phase margin
- Despite line and load variations, the loop gain remains similar

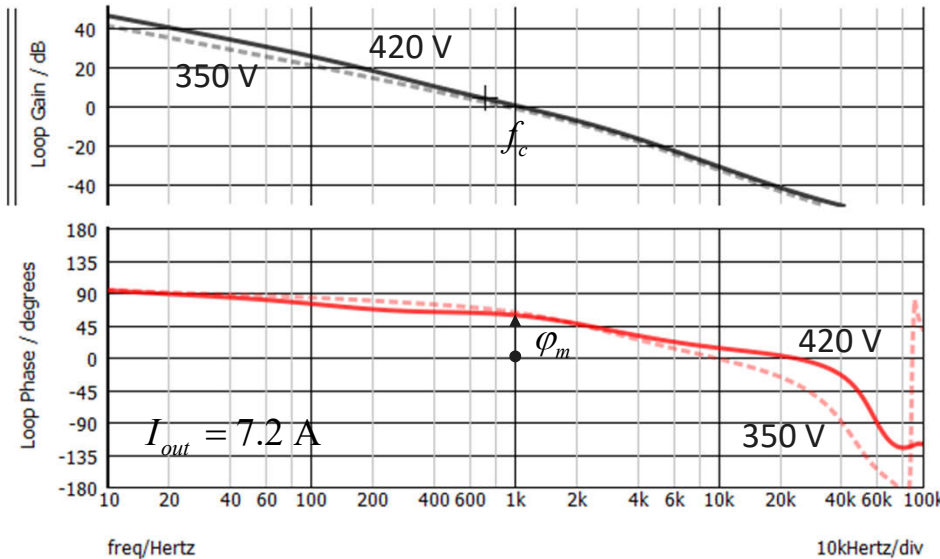

Loop gain, different input voltages

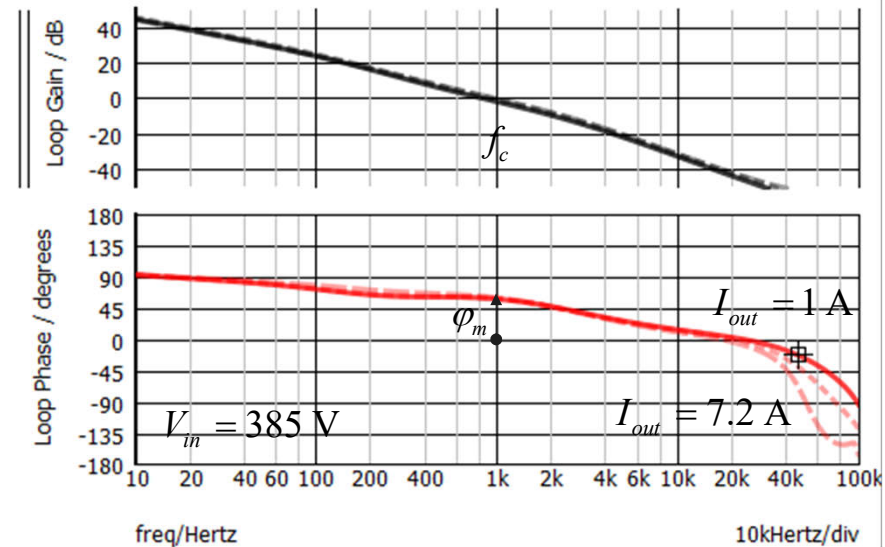

Loop gain, different output currents

Typical Application Schematic of NCP13992

- The part observes the resonating current via a capacitive differentiator on pin CS

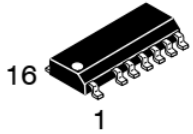
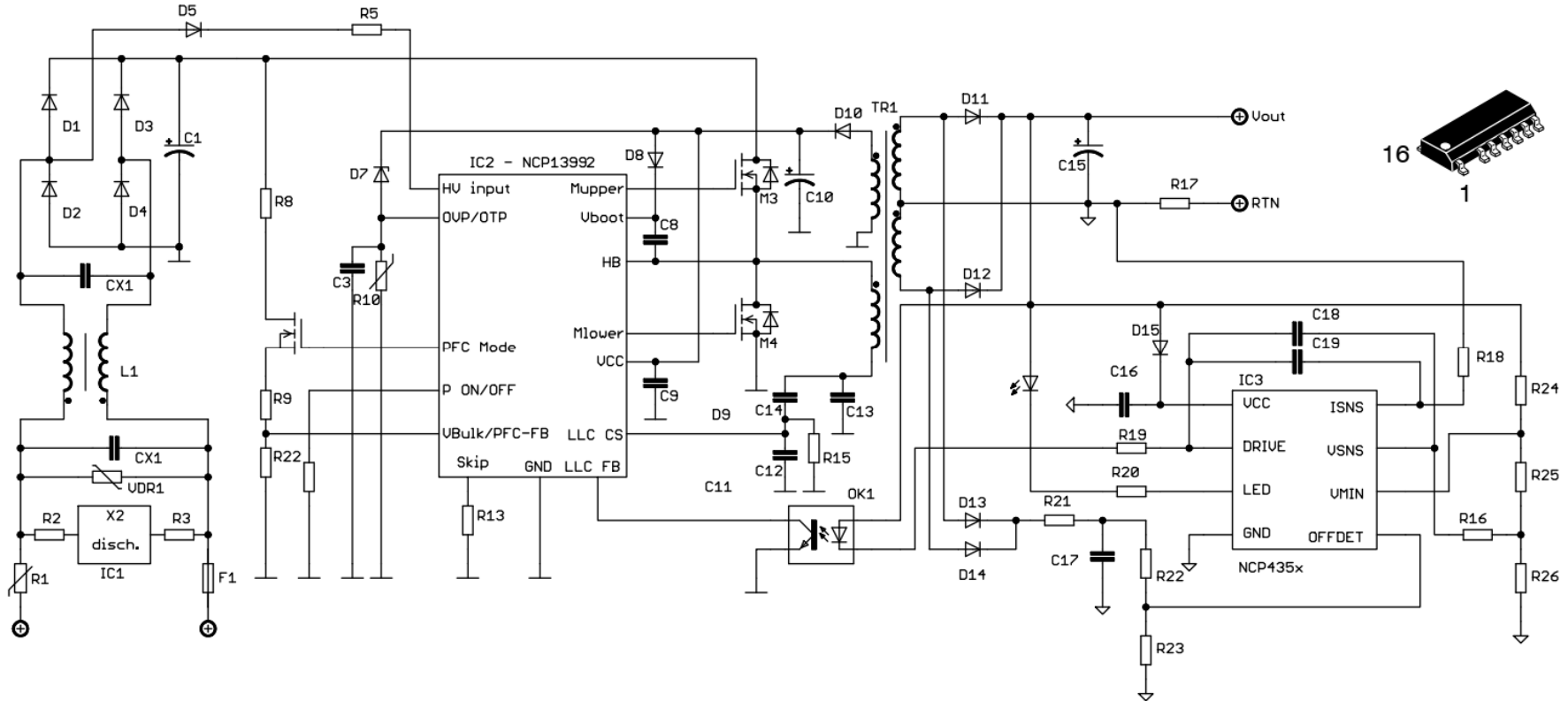

Agenda

- Hard and Soft Switching
- What is an LLC Converter?
- Controlling the Switching Frequency
- Closing the Loop
- Charge-Controlled Operation I
- Charge-Controlled Operation II
- Current-Mode Control
- **Time-Shift Control**
- An Overview of Available LLC Controllers

Time-Shift Control of LLC Converters

- The controller inserts a pause before the 0-A crossing point of the resonating current
- For ZVS operations, the resonant current lags the half-bridge voltage
- The feedback loop modulates the delay and adjusts the output power

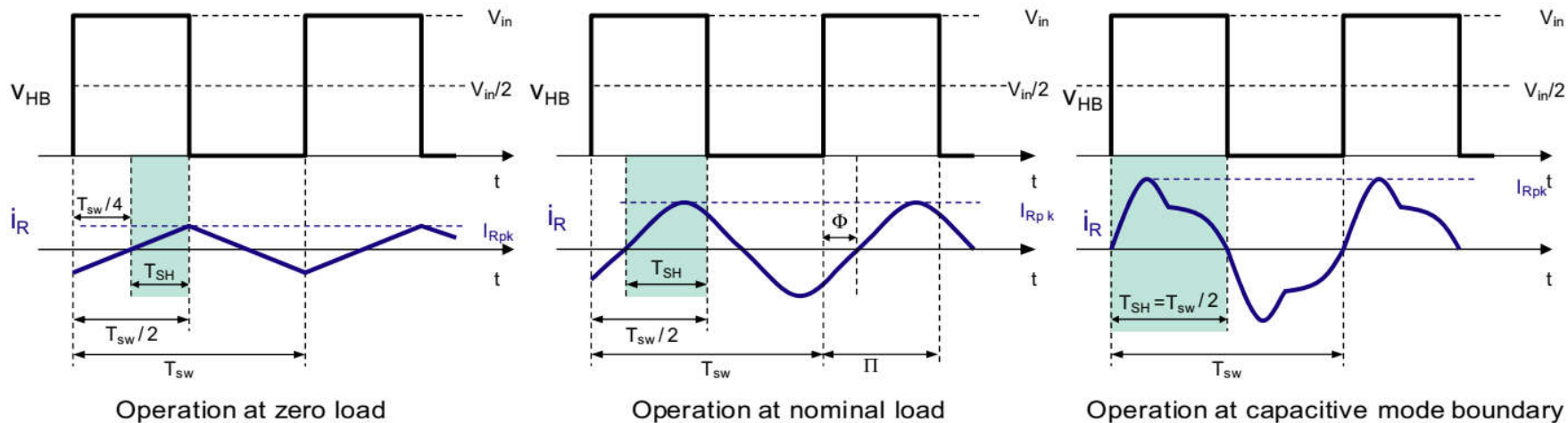

Modifying the Frequency Modulator

- It is possible to insert a delay by **pausing** the charge/discharge current
- The pause duration depends on the resonating current approaching the 0-A point

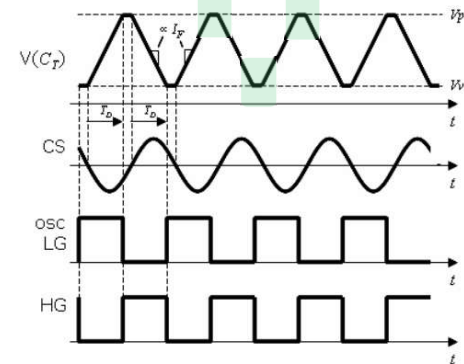
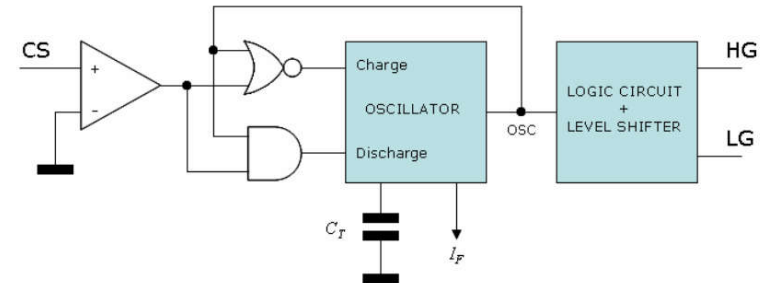
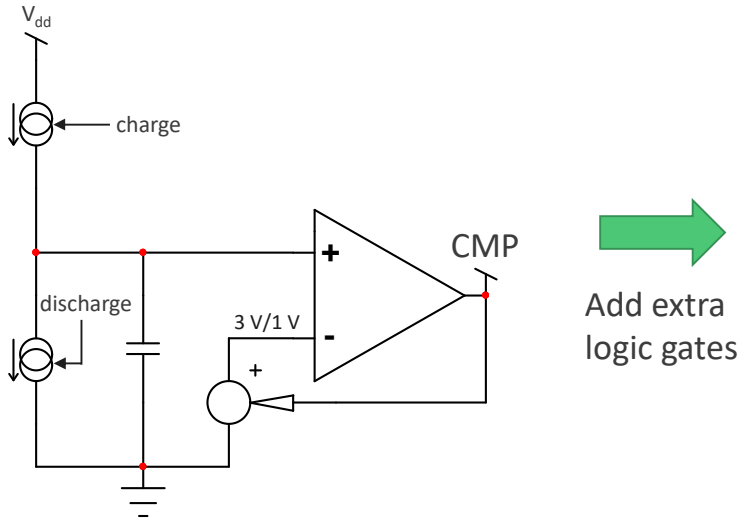

STCMB1

- ✓ 50% duty ratio naturally guaranteed
- ✓ Need to set the min/max switching frequencies

Internal Circuitry for the Half-Bridge Driver

- The STCMB1 features automatic dead-time management for ZVS operation

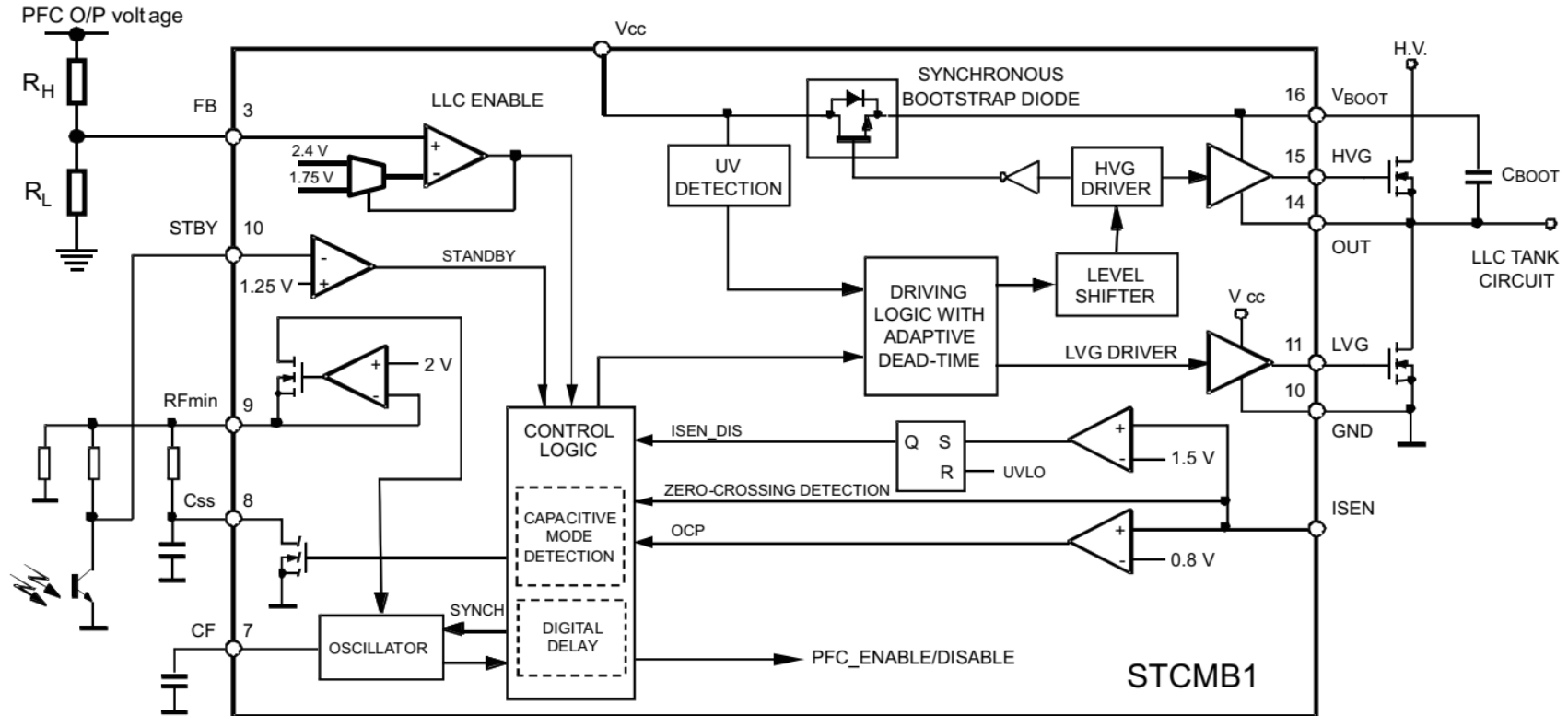

SIMPLIS Simulation of the Time-Shifted-Controlled LLC

- A delay is inserted by modulating the charge/discharge current of the timing capacitor
- The feedback current modulates the delay and the switching frequency indirectly

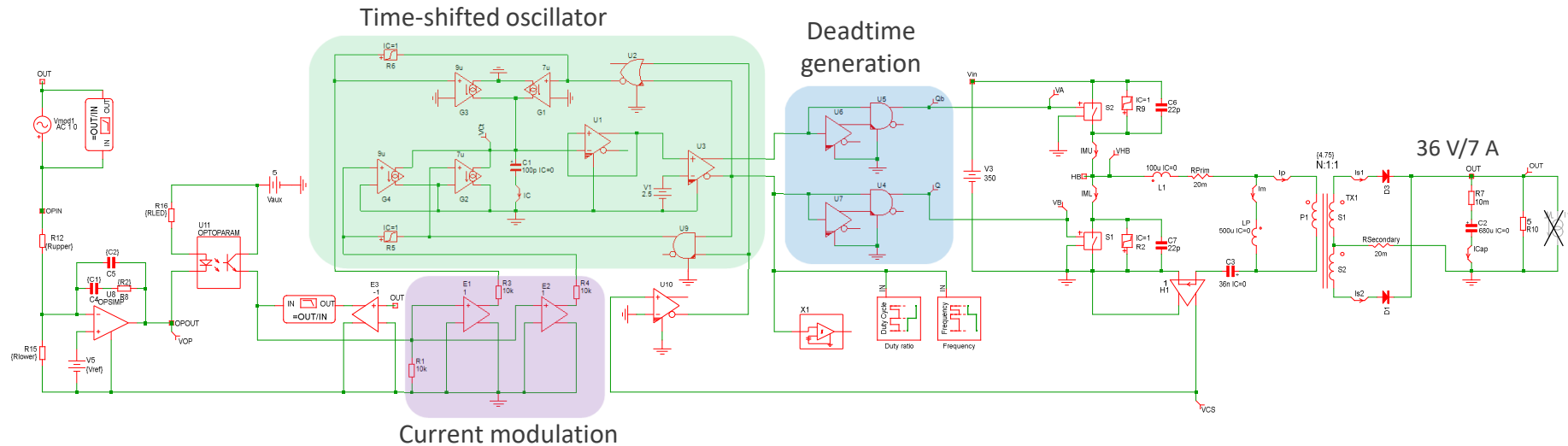

- ✓ A simple type 2 compensator is enough to stabilize the converter
- ✓ Current sensing can be implemented via a simple resistance or a capacitive divider

Typical Operating Waveforms

- The pause in the charge/discharge process is clearly visible in this 36-V LLC converter

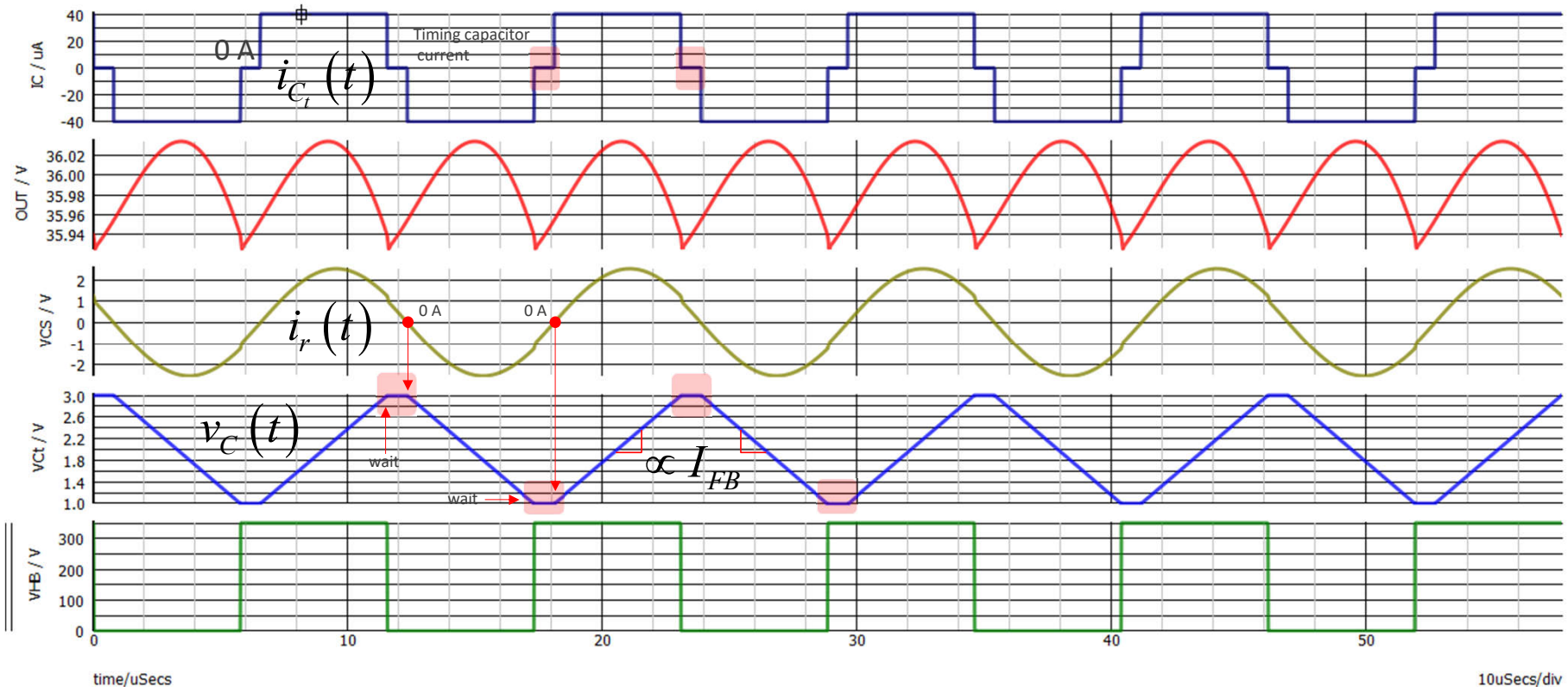

Time-Shift-Controlled Compensated LLC Converter

- The converter is compensated for a 1-kHz crossover frequency with a 60° phase margin
- The response is stable at various conditions but shows some variability in crossover

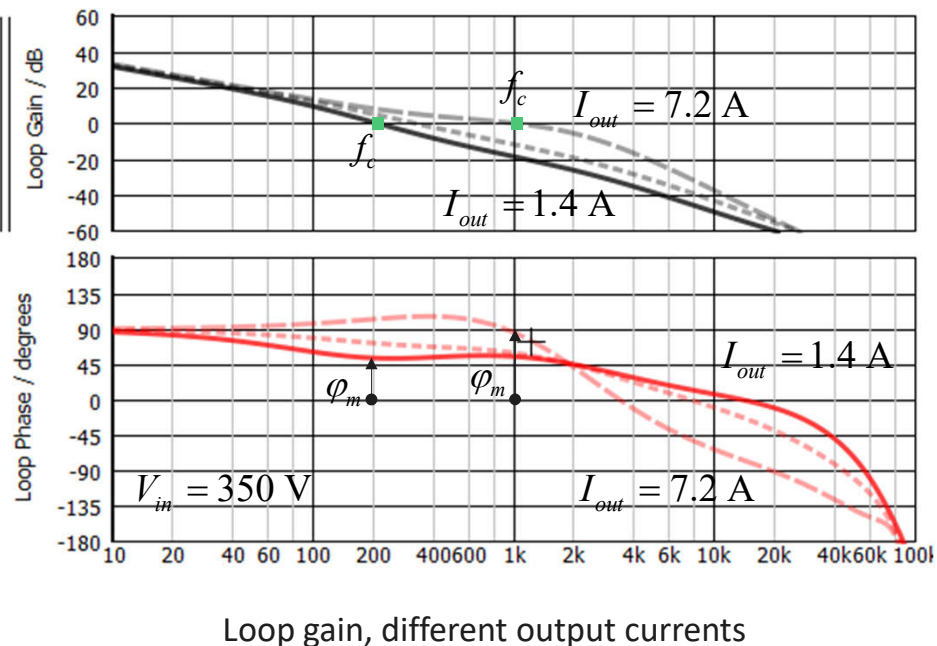
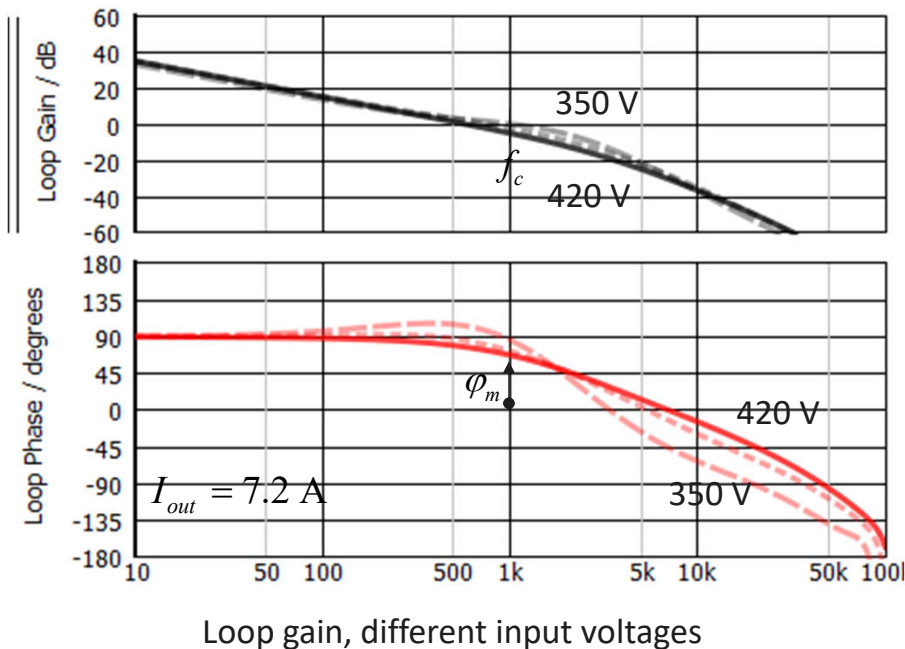

Combining LLC Control and PFC in a Combo Chip



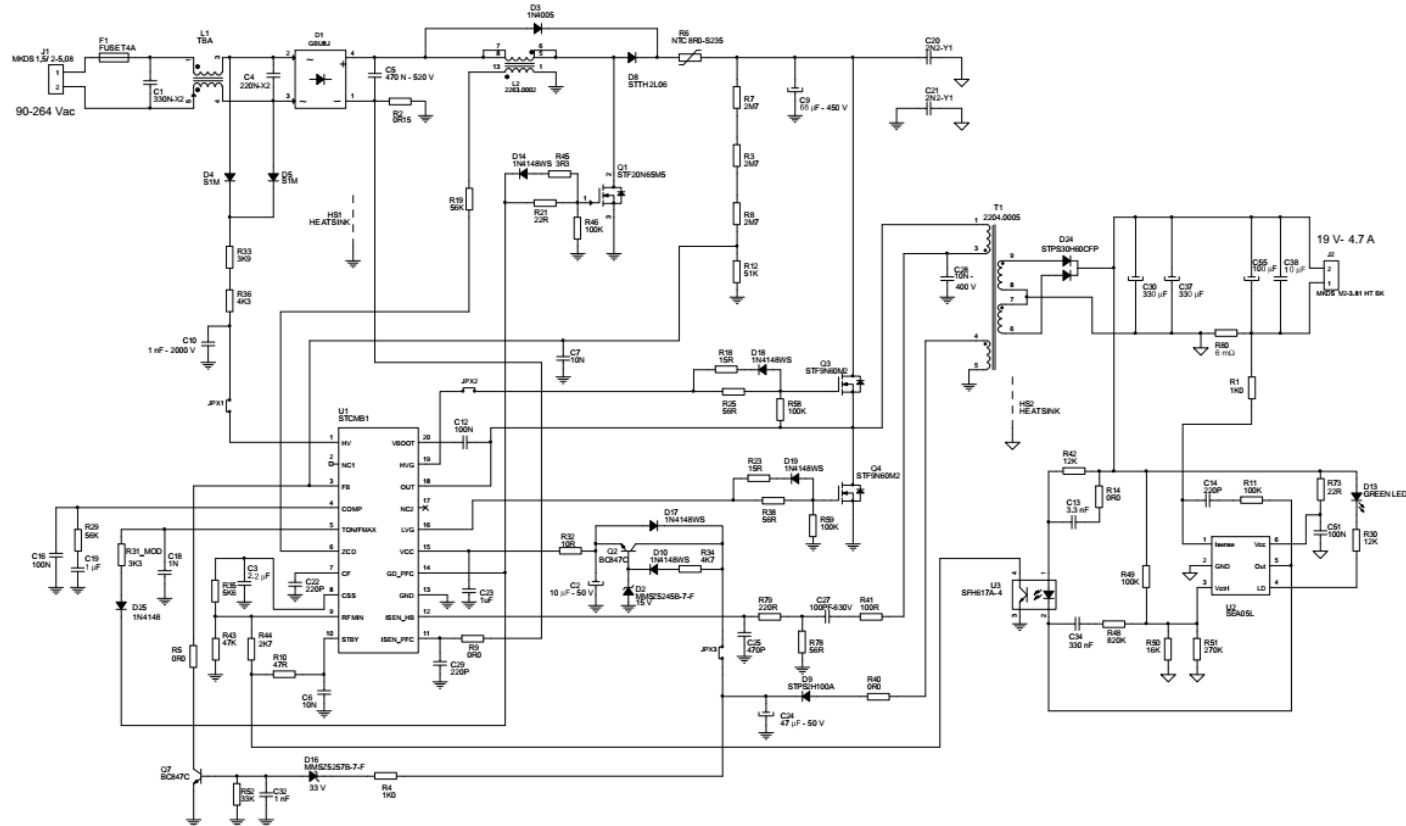







- The controller includes a PFC and the time-shift control section



Agenda

- Hard and Soft Switching
- What is an LLC Converter?
- Controlling the Switching Frequency
- Closing the Loop
- Charge-Controlled Operation I
- Charge-Controlled Operation II
- Current-Mode Control
- Time-Shift Control
- An Overview of Available LLC Controllers

An Overview of Commercially-Available LLC Controllers

Part-Number	High-Voltage Drivers	Variable-Frequency Control	Charge Control	Current-Mode Control	Time-Shifted Control	Combo LLC+PFC	Package	Brand
NCP13992	√	—	—	√	—	—	SO-16	
NCP4390	—	—	√	—	—	—	SO-16	
TEA2017	√	—	√	—	—	√	SO-16	
TEA19161	√	—	√	—	—	—	SO-16	
STCMB1	√	—	—	—	√	√	SO-20W	
L6699	√	√	—	—	—	—	SO-16	
HR1002A	√	√	—	—	—	—	SO-16	
HR1211	√	—	—	√	—	√	SO-20	
ICE2HS01G	—	√	—	—	—	—	SO-20	
IRS27951	√	√	—	—	—	—	SO-8	

Conclusion

- An LLC converter operated in variable-frequency mode exhibits a complicated ac response
- It is difficult and perilous to maintain a safe phase margin depending on conditions
- Crossover frequency is constrained to modest values
- The charge-controlled LLC converter offers a simpler and predictable ac response
- A simple type 2 compensator is enough to ensure reliable operations
- High crossover frequencies become possible with good margins
- Variations around this theme exist and bear different names
- Current-mode control also exists and offers interesting characteristics
- Time-shifted-controlled LLC brings a different scheme and simplifies compensation